

ITEM NO.	QTY.	PART NUMBER	DESCRIPTION
1	4	3500-1262012-15A	M4 x 12mm SFHCS, Blue Dyed Magni-565 w/Microspheres
2	1	NSS	Cover, SR-48
3	1	NSS	O-Ring 32mm X 1mm Buna
4	1	NSS	Stem Sub-Assembly
5	1	NSS	O-ring AS568A-008
6	1	NSS	O-ring AS568-023
7	1	NSS	Piston, SR-048
8	1	NSS	Body, SR-48
9	1	3500-1964010-15	M5 x 10 Dog Point Setscrew Black Oxide
10	1	3700-60-1873	Switch Plunger, Side Switch
11	1	3610-0904400-20	.28 Dia x .77 Lg. SS Compression Spring
12	1	NSS	O-RING, AS568-014, 1/2x1/16
13	1	9160-CON-5	Connector Block Assembly, SR-048
14	2	3500-1058020-15A	M3 x 20mm SHCS Blue Dyed Magni-565, ND Microspheres
15	1	3610-6402500-20	Assist Spring, SR-048 P05
15	1	3610-7202500-20	Assist Spring, SR-048 P10
15	1	3610-7202501-20	Assist Spring, SR-048 P15

Rev.	Description	Initiator	Date
01	Initial Drawing	DAW	3/15/2013
02	ECO-11161; Added C5 boot kit to sheet 2	DAW	7/8/2013

- NSS - Not sold separately.
- 9160-SEAL-048 Seal Kit contains items 5, 6 and 12.
- 9005-60-1038 Piston & Body Kit contains items 7 and 8.
- 9160-CON-5 Switch and Connector Block Assembly contains items 11, 12, 13 and 14.
- 9160-STEMCOVKIT-048 Stem and Cover Kit contains items 1 thru 4.

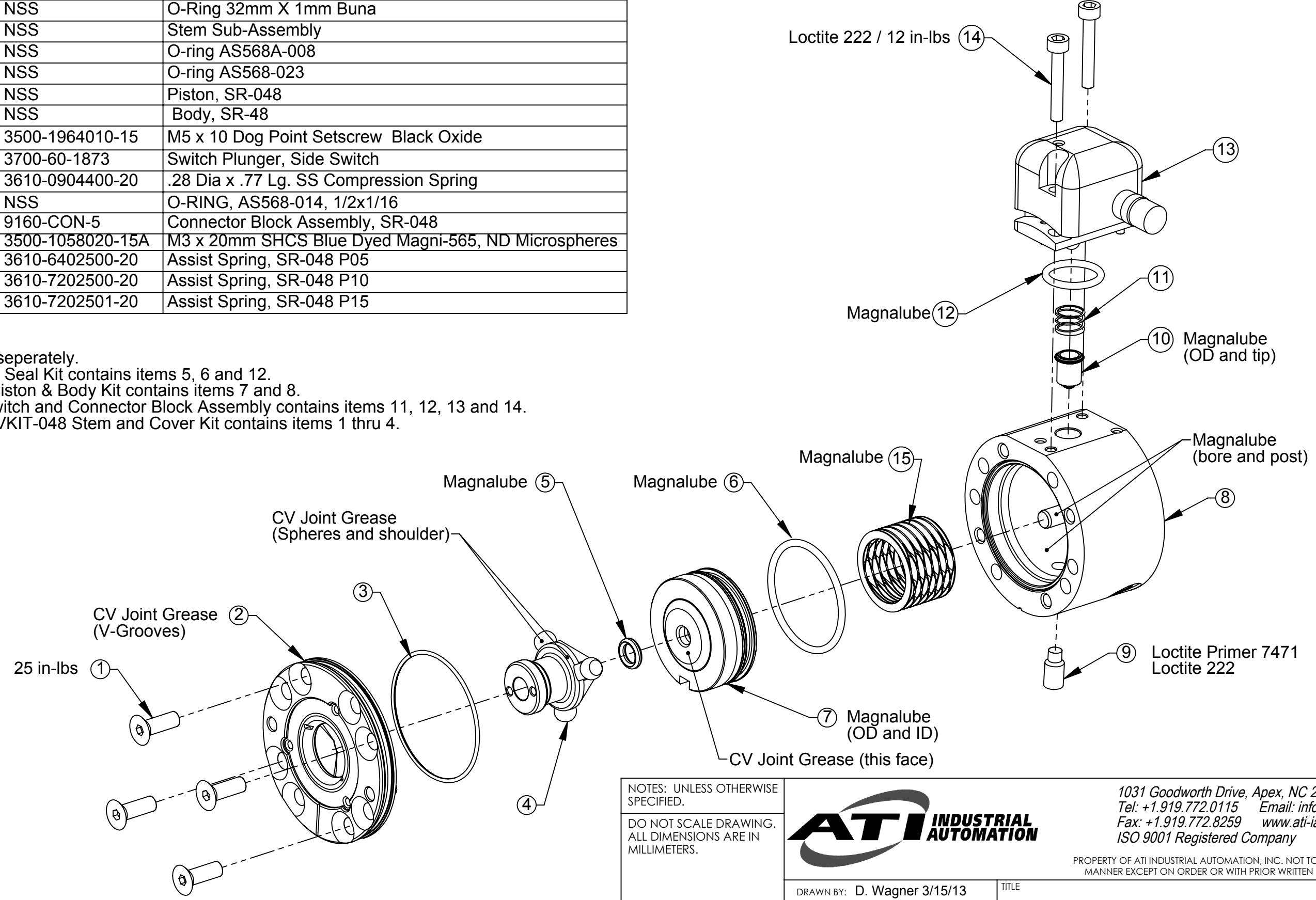

NOTES: UNLESS OTHERWISE SPECIFIED.

DO NOT SCALE DRAWING. ALL DIMENSIONS ARE IN MILLIMETERS.

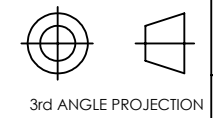

1031 Goodworth Drive, Apex, NC 27539, USA
 Tel: +1.919.772.0115 Email: info@ati-ia.com
 Fax: +1.919.772.8259 www.ati-ia.com
 ISO 9001 Registered Company

PROPERTY OF ATI INDUSTRIAL AUTOMATION, INC. NOT TO BE REPRODUCED IN ANY MANNER EXCEPT ON ORDER OR WITH PRIOR WRITTEN AUTHORIZATION OF ATI.

DRAWN BY: D. Wagner 3/15/13		TITLE	
CHECKED BY: DKL 4/3/13		SR-48 Collision Sensor Assembly Replacement Parts	
PROJECT # 101217-3	SHEET 1 OF 2	SCALE 1:1	SIZE B
		DRAWING NUMBER 9230-60-1168	REVISION 02

ITEM NO.	QTY.	PART NUMBER	DESCRIPTION
1	3	NSS	M2.5 x 6mm SFHCS Black Oxide, ND Microspheres
2	1	NSS	Shield Retainer, SR-048
3	1	NSS	Debris Shield, SR-048
4	2	NSS	Garter Spring
5	1	NSS	C5 Boot

NSS - Not sold separately.

Rev.	Description	Initiator	Date
-	See Sheet1	-	-

9160-FLEXBOOT-048
 (Repair Kit for C5 Coolant Protection Boot)

9160-SHIELD-048
 (Repair Kit for C2 Weld Splatter Shield)

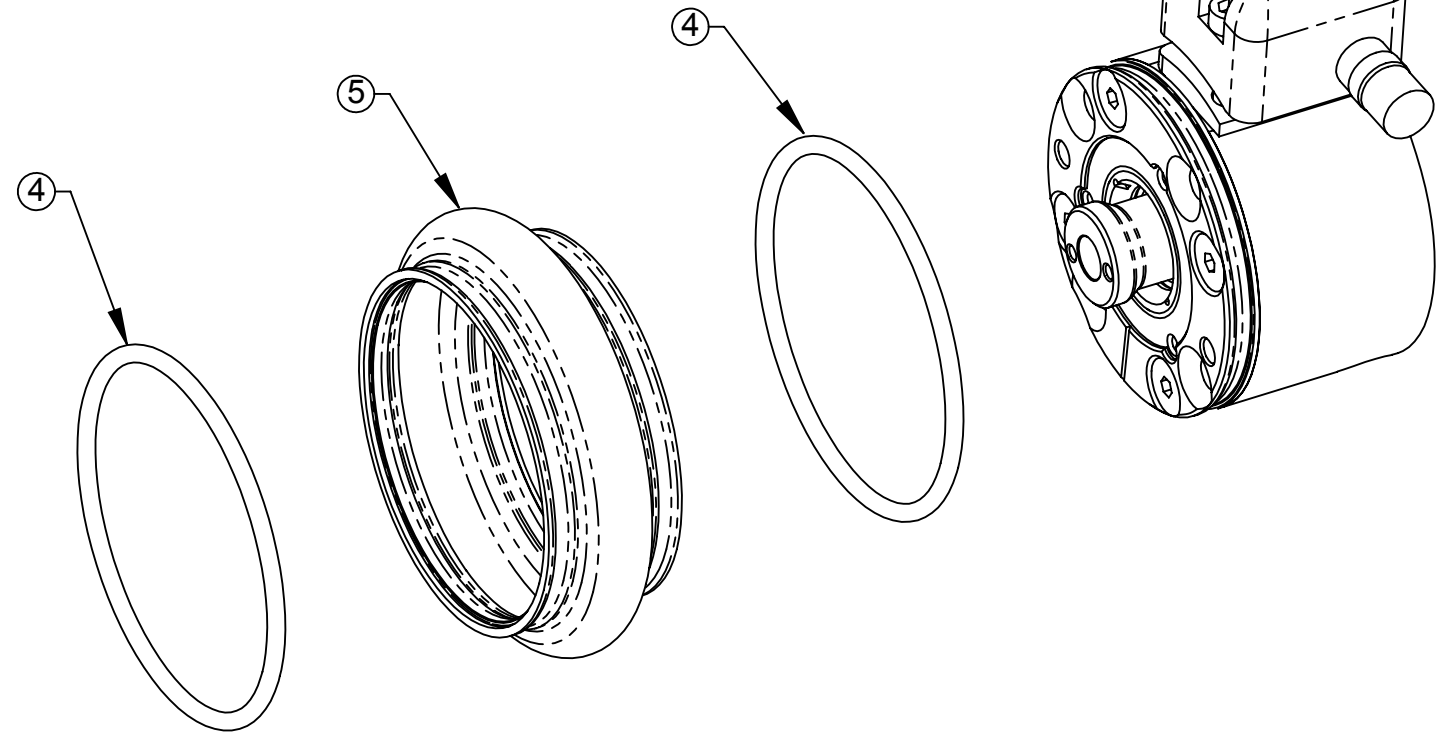
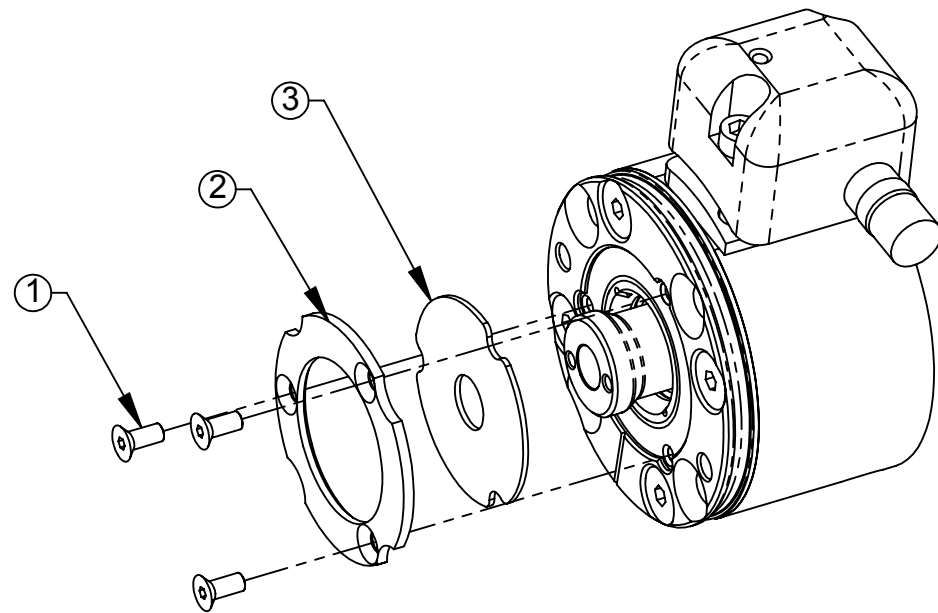

NOTES: UNLESS OTHERWISE SPECIFIED.

DO NOT SCALE DRAWING. ALL DIMENSIONS ARE IN MILLIMETERS.

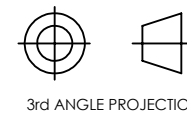

1031 Goodworth Drive, Apex, NC 27539, USA
 Tel: +1.919.772.0115 Email: info@ati-ia.com
 Fax: +1.919.772.8259 www.ati-ia.com
 ISO 9001 Registered Company

PROPERTY OF ATI INDUSTRIAL AUTOMATION, INC. NOT TO BE REPRODUCED IN ANY MANNER EXCEPT ON ORDER OR WITH PRIOR WRITTEN AUTHORIZATION OF ATI.

DRAWN BY: D. Wagner 3/15/13		TITLE	
CHECKED BY: DKL 4/3/13		SR-48 Collision Sensor Assembly Replacement Parts	
PROJECT #	101217-3	SHEET	OF 2
SCALE	1:1	SIZE	B
DRAWING NUMBER	9230-60-1168		REVISION
			02