

ITEM NO.	QTY.	PART NO.	DESCRIPTION
1	4	3500-1265025-15	M6 x 25mm SFHCS
2	1	9160-STEMCOVKIT-131*	Cover Plate Sub-assembly
3	1	(Includes Items 1 & 4)	Stem Sub-assembly
4	1	3410-0001202-01	Cover O-ring
5	2	3500-1058020-15A	M3 x 20 SHCS, Metric Blue, ND Microspheres
6	1	3700-60-1698	Spring Plate
7	1	3610-1902601-20	Actuation Spring
8	2	3700-60-1702	5mm x 12mm Standoff
9	1	3700-60-1699	Actuation Plate
10	2	9160-SWITCHKIT-131	M2.5 x 6mm SFHCS, Black Oxide
11	1	(Includes Item 16)	Spring Stop
12	1		Switch Carrier Spring
13	1		Switch Assembly
14	1	3490-0001009-01	1/8" Pipe Plug, Air Supply Port
	1	3490-0001021-01	Rc 1/8" Pipe Plug, Air Supply Port
15	1	3500-1958008-12A	M3 x 8 SHSS, Black Oxide, N.D. Microspheres
16	1	3700-60-1308	Wire Channel Gasket
	1	3700-60-1663	Molded Wire Channel Gasket (Use with C1, C3 and C5 Boots)
17	1	9160-CON-2	Connector Block Assembly

Rev.	Description	Initiator	Date
04	ECO 16276: Replaced 9160-CON-1 with 9160-CON-2. Removed ** Units with grey covers use 9160-CON-2. note. Removed Revision block from Sheet 2.	TBC	11/27/2017

\* For units with grey covers add "-S" to end of part number.

222MS / 70 in-lbs ①

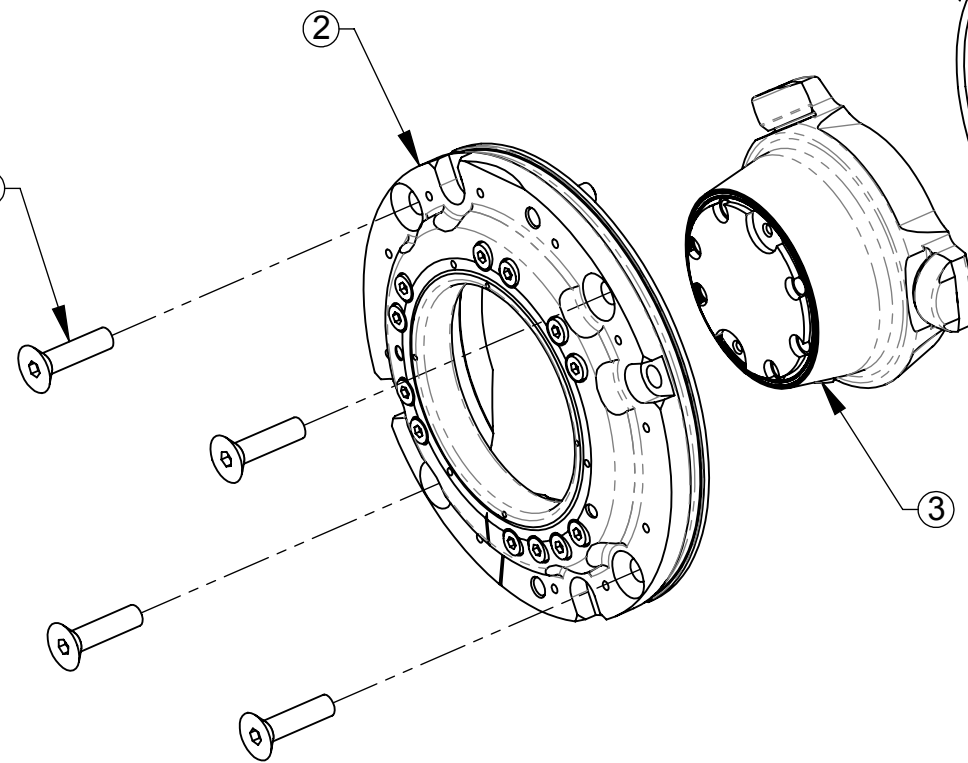

222MS / 12 in-lbs ⑤

④

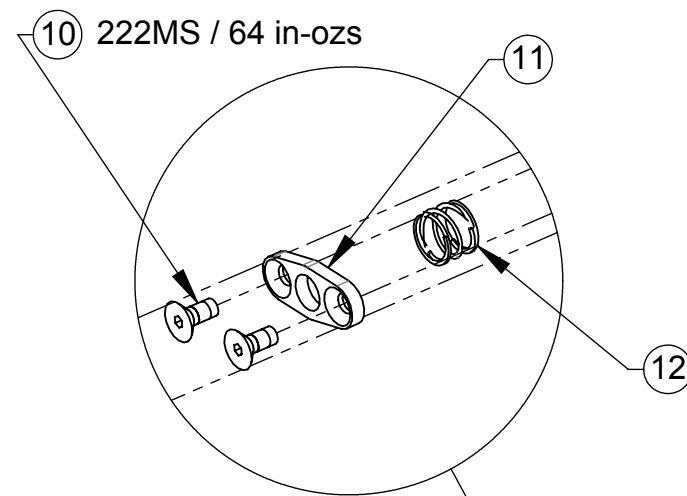
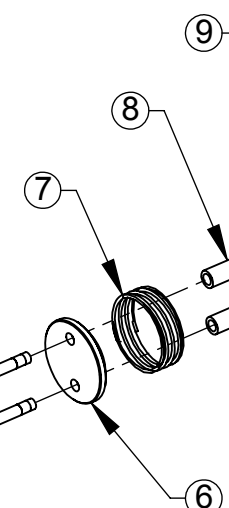

DETAIL A  
SCALE 1 : 1

222MS / 64 in-ozs

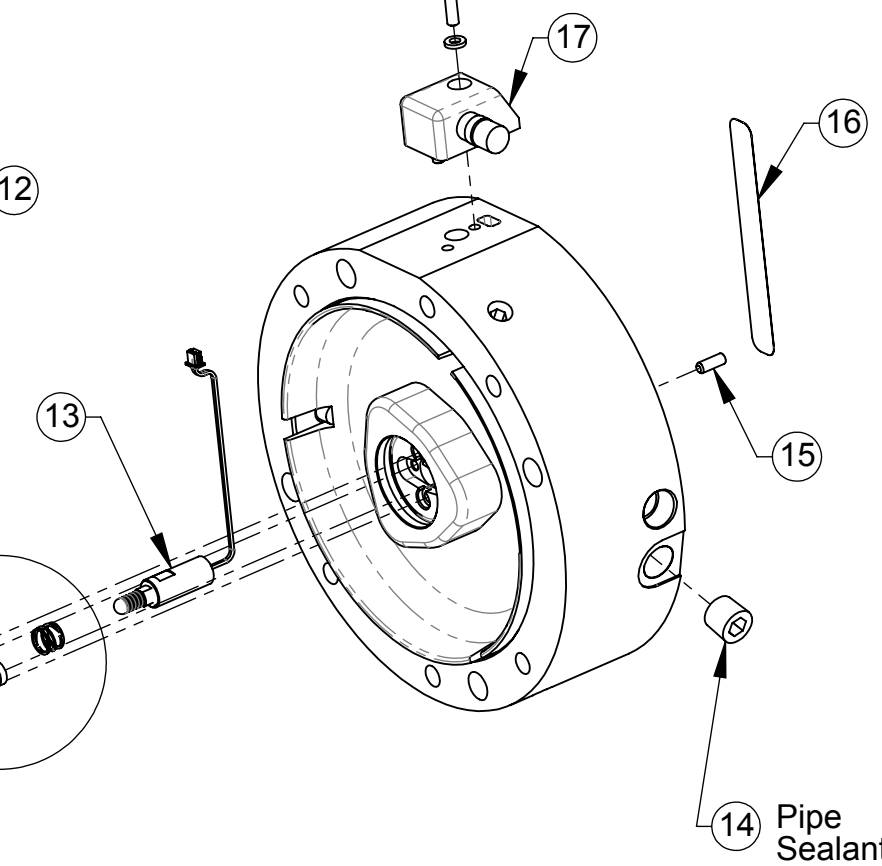

Notes:

1. See sheet 2 for optional boots and shields.
2. Apply the specified grade of Loctite / tighten fasteners to the specified torque.

NOTES: UNLESS OTHERWISE SPECIFIED.

DO NOT SCALE DRAWING. ALL DIMENSIONS ARE IN MILLIMETERS.

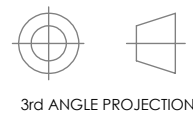

1031 Goodworth Drive, Apex, NC 27539, USA  
 Tel: +1.919.772.0115 Email: info@ati-ia.com  
 Fax: +1.919.772.8259 www.ati-ia.com  
 ISO 9001 Registered Company

PROPERTY OF ATI INDUSTRIAL AUTOMATION, INC. NOT TO BE REPRODUCED IN ANY MANNER EXCEPT ON ORDER OR WITH PRIOR WRITTEN AUTHORIZATION OF ATI.

DRAWN BY: D. Wagner 4/25/2008		TITLE	
CHECKED BY: W.B. 5/8/2008		SR-131 Collision Sensor Assembly	
PROJECT # 070517-2	SHEET 1 OF 2	SCALE 1:2	SIZE B
		DRAWING NUMBER 9230-60-1132	REVISION 04

ITEM NO.	QTY.	PART NO.	DESCRIPTION
1	1	NSS	Upper Boot Retainer
2	14	NSS	M3 x 8 SFHCS, Black Oxide, Microspheres Epoxy
3	1	NSS	Lower Boot Retainer
4	1	3700-60-1307	Boot
5	1	3410-0001202-01	O-Ring, 105mm ID x 2mm
6	1	NSS	Weld Splatter Shield
7	1	NSS	EDPD Rubber Seal
8	2	NSS	Garter Spring
9	1	3700-60-1563	Flexible Boot
10	1	3700-60-1663	Molded Wire Channel Gasket

NSS - Not sold separately - purchase the appropriate repair kit.

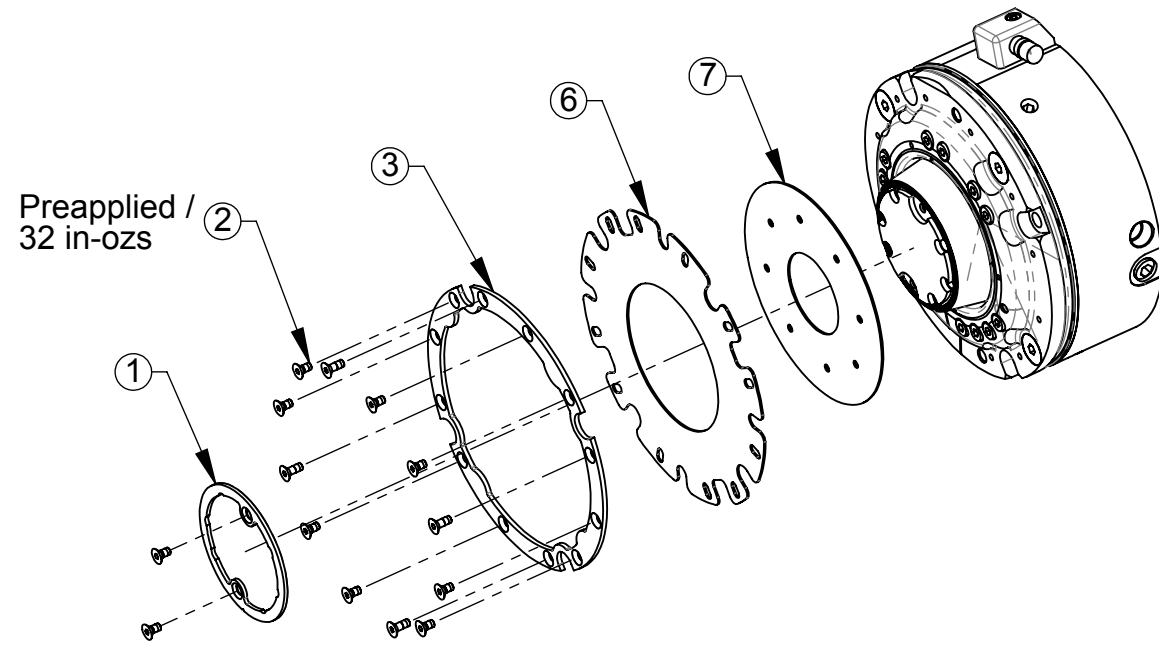

**9160-SHIELD-131**  
**(Repair Kit for C2 Weld Splatter Shield)**

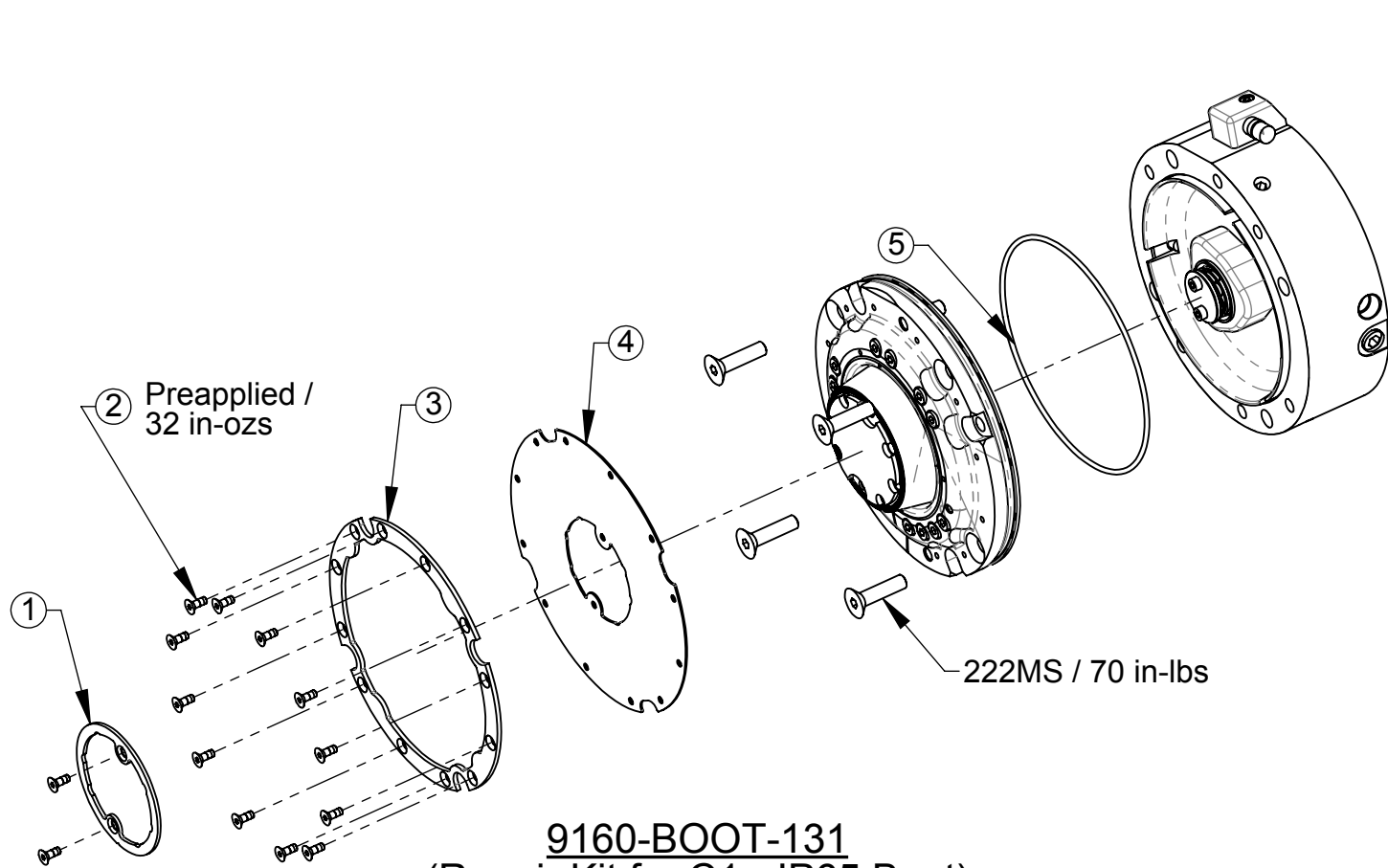

**9160-BOOT-131**  
**(Repair Kit for C1 - IP65 Boot)**

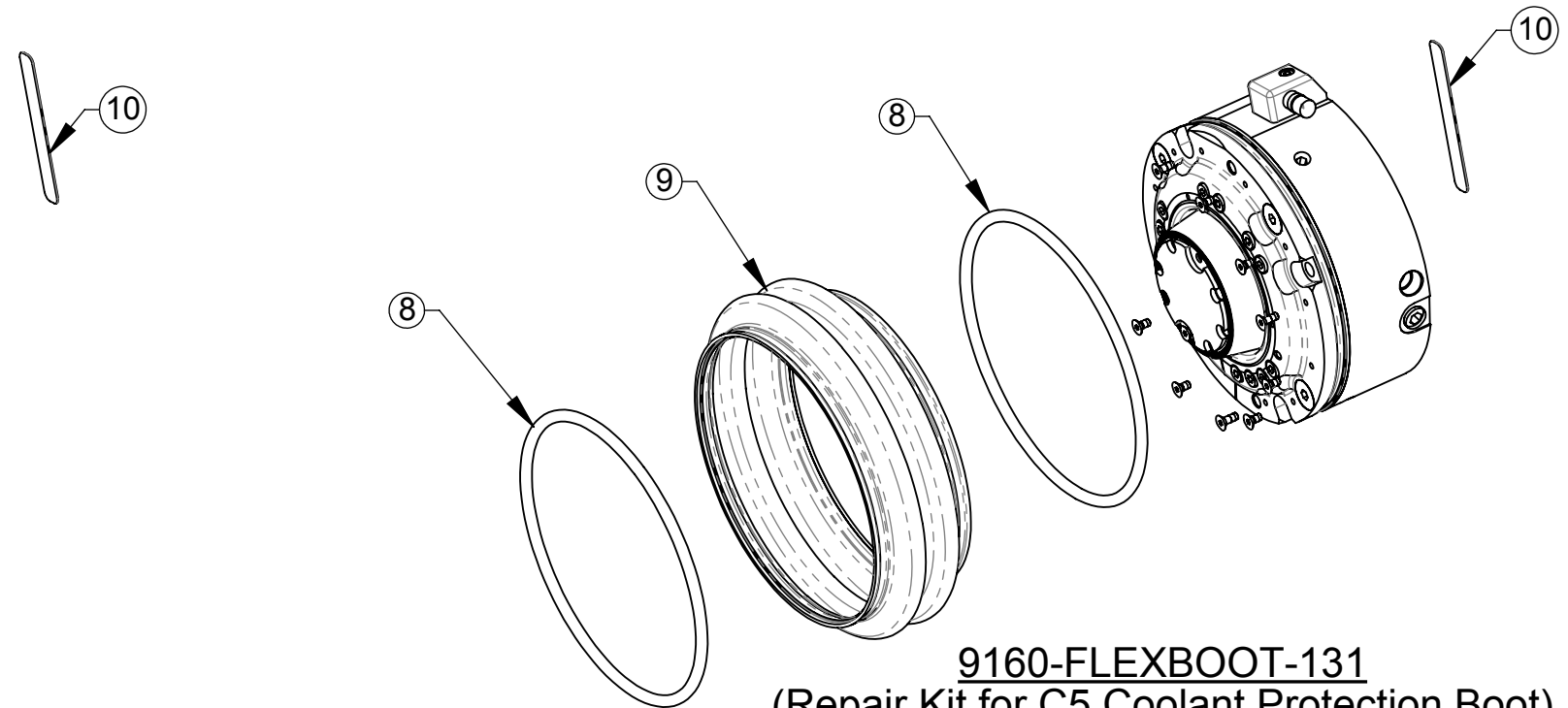

**9160-FLEXBOOT-131**  
**(Repair Kit for C5 Coolant Protection Boot)**

NOTES: UNLESS OTHERWISE SPECIFIED.

DO NOT SCALE DRAWING. ALL DIMENSIONS ARE IN MILLIMETERS.



3rd ANGLE PROJECTION



1031 Goodworth Drive, Apex, NC 27539, USA  
Tel: +1.919.772.0115 Email: info@ati-ia.com  
Fax: +1.919.772.8259 www.ati-ia.com  
ISO 9001 Registered Company

PROPERTY OF ATI INDUSTRIAL AUTOMATION, INC. NOT TO BE REPRODUCED IN ANY MANNER EXCEPT ON ORDER OR WITH PRIOR WRITTEN AUTHORIZATION OF ATI.

DRAWN BY: D. Wagner 4/25/2008

CHECKED BY: W.B. 5/8/2008

TITLE

SR-131 Collision Sensor Assembly

PROJECT # 070517-2 SHEET 2 OF 2

SCALE  
1:3

SIZE  
B

DRAWING NUMBER  
9230-60-1132

REVISION  
04