

Rev.	Description	Initiator	Date
01	Initial Version	DAW	6/27/2006

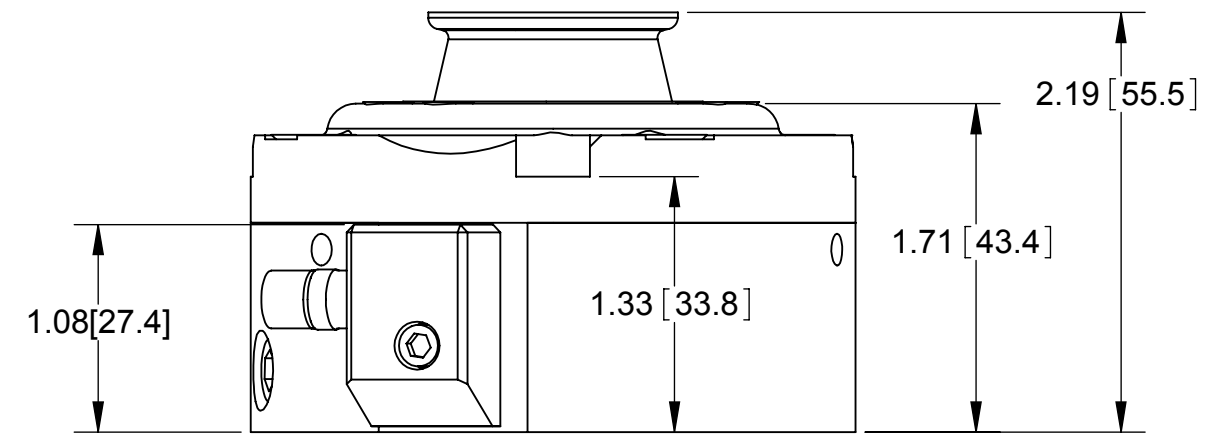

3 POLE "NANO" CONNECTOR
 (MATES WITH SNAP PLUG OR
 THREADED COUPLER PLUG)

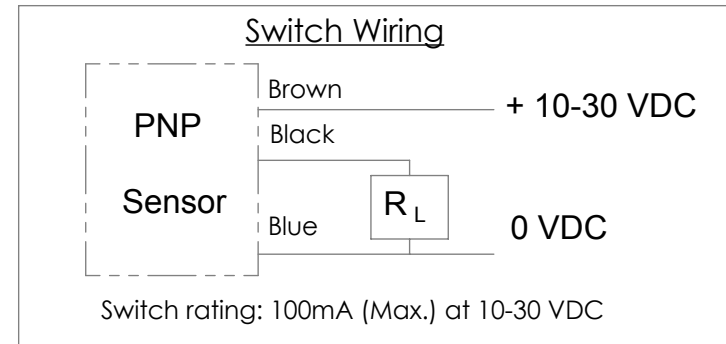
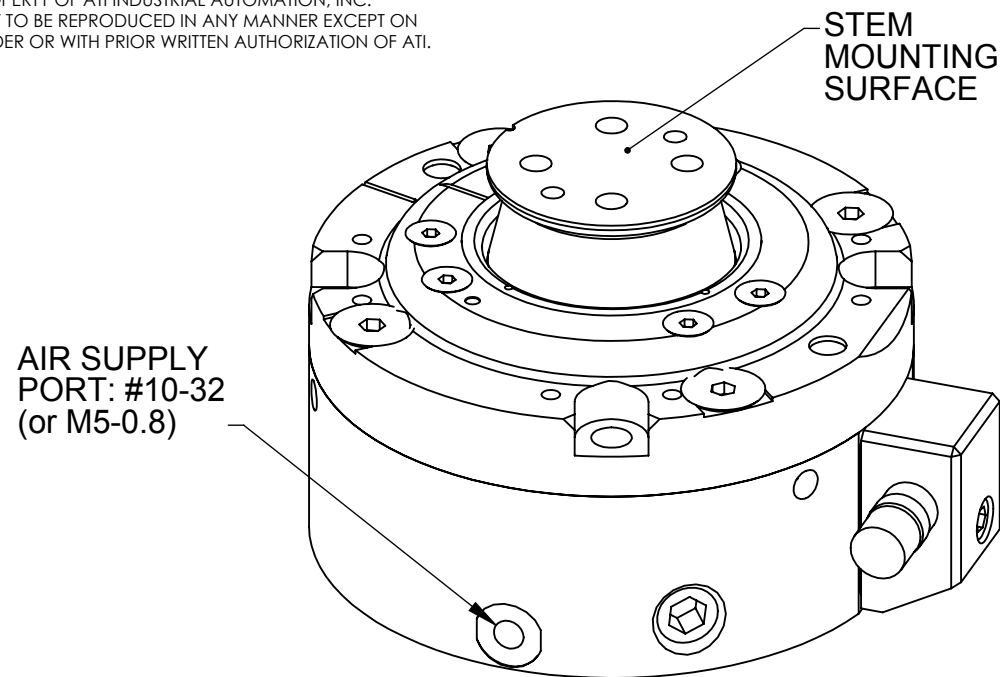
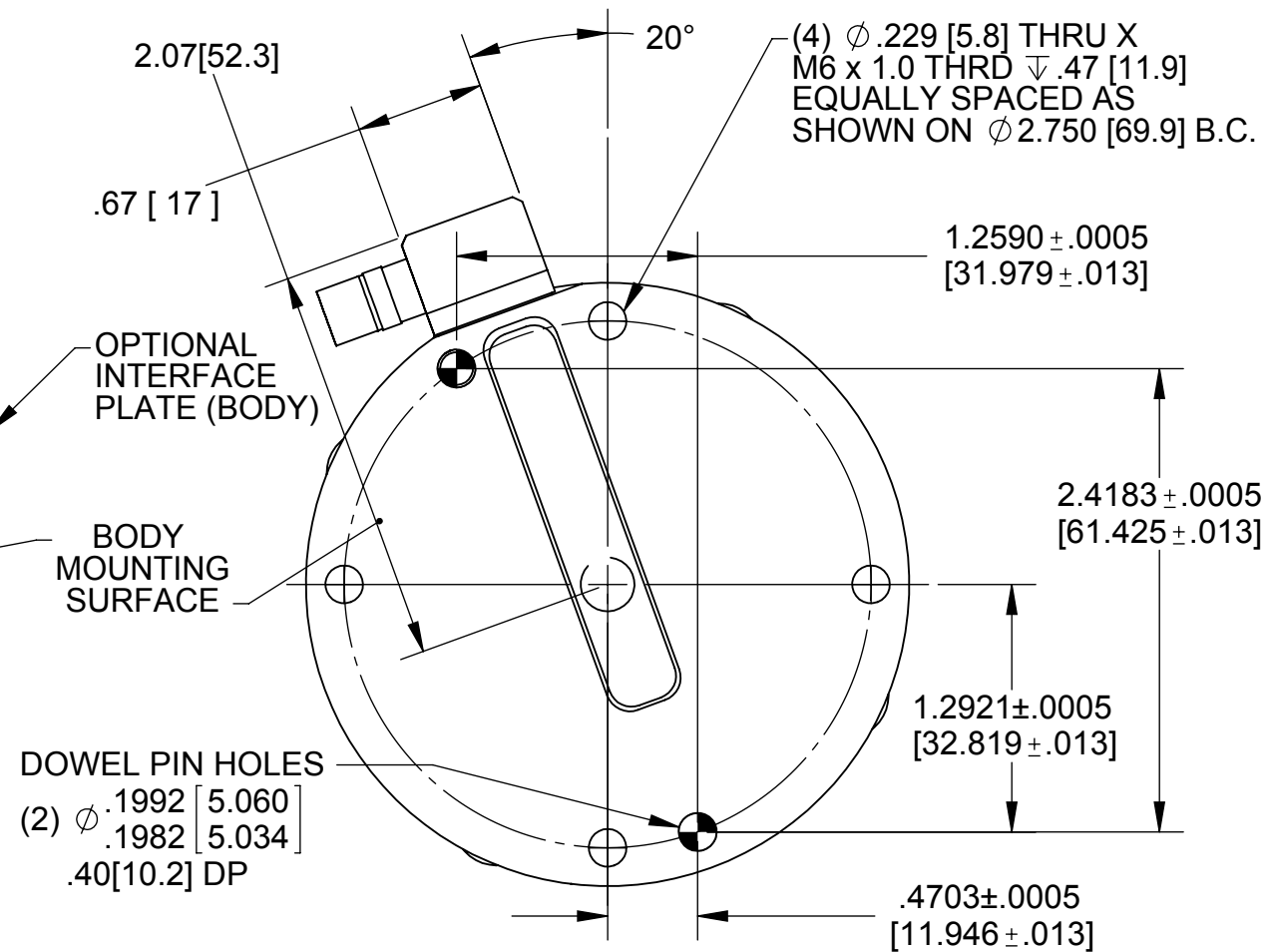
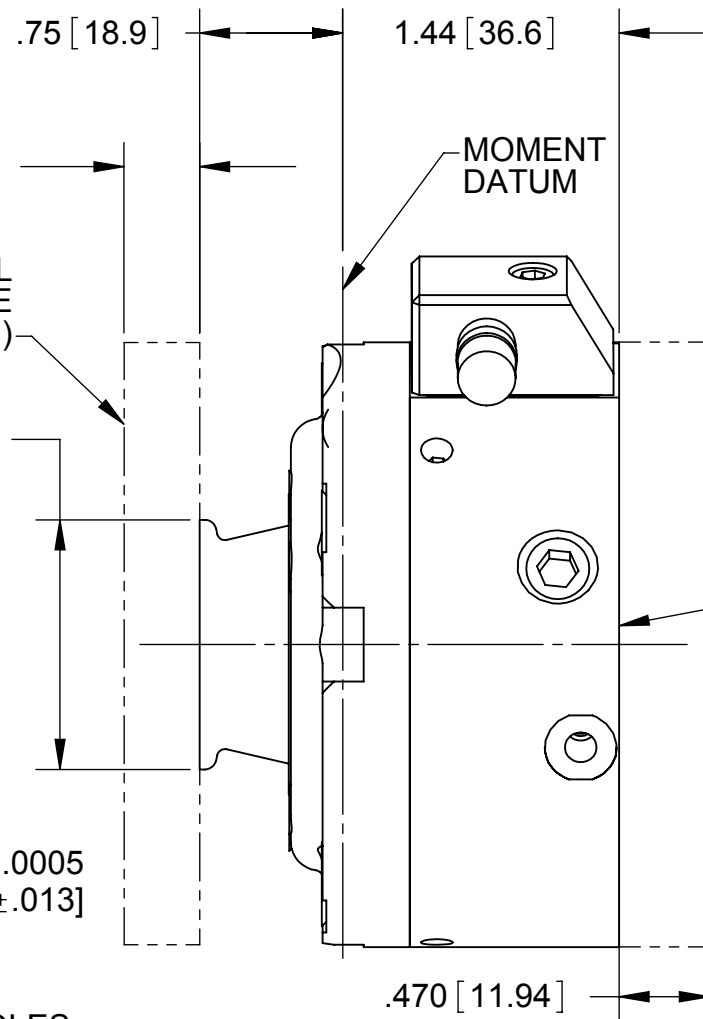
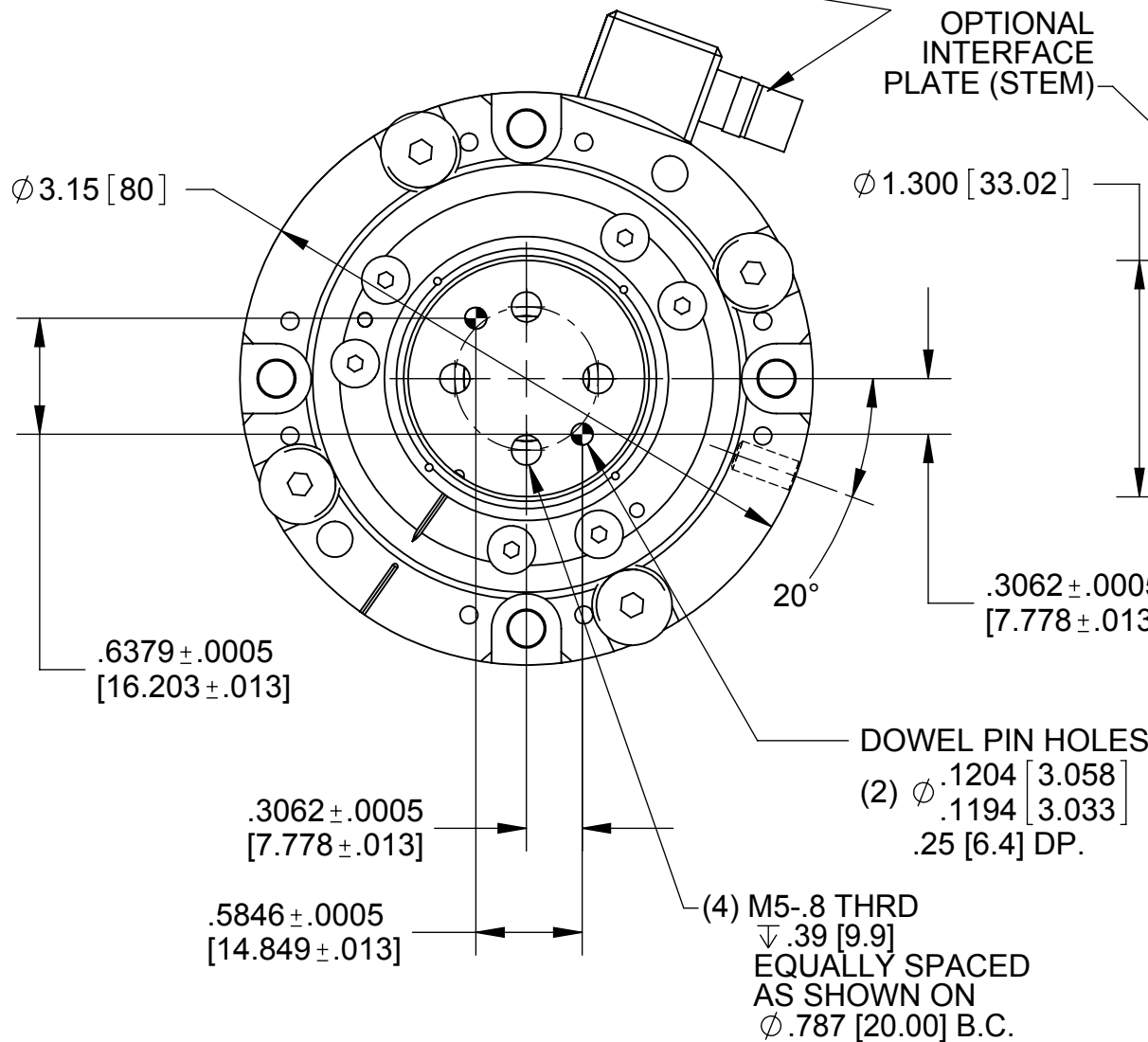

NOTES: UNLESS OTHERWISE SPECIFIED
 DO NOT SCALE DRAWING. DRAWN IN SOLIDWORKS.
 ALL DIMENSIONS ARE IN MILLIMETERS.

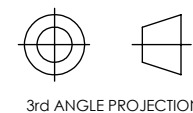

1031 Goodworth Drive, Apex, NC 27539, USA
 Tel: +1.919.772.0115 Email: info@ati-ia.com
 Fax: +1.919.772.8259 www.ati-ia.com
 ISO 9001 Registered Company

DRAWN BY: D. Wagner 6/27/06	TITLE SR-82 Collision Sensor Assembly		
CHECKED BY: MLG 7/25/06	SCALE 1:1	SIZE B	DRAWING NUMBER 9230-60-1094-01
WEIGHT LBS: --	PRODUCT RELEASE # 051026-2 DATE:		
ASSEMBLY REF:	SHEET 1 OF 1		