

Rev.	Description	Initiator	Date
11	Eco 16278; Replaced Sensor Wiring Diagram.	LJH	11/21/17

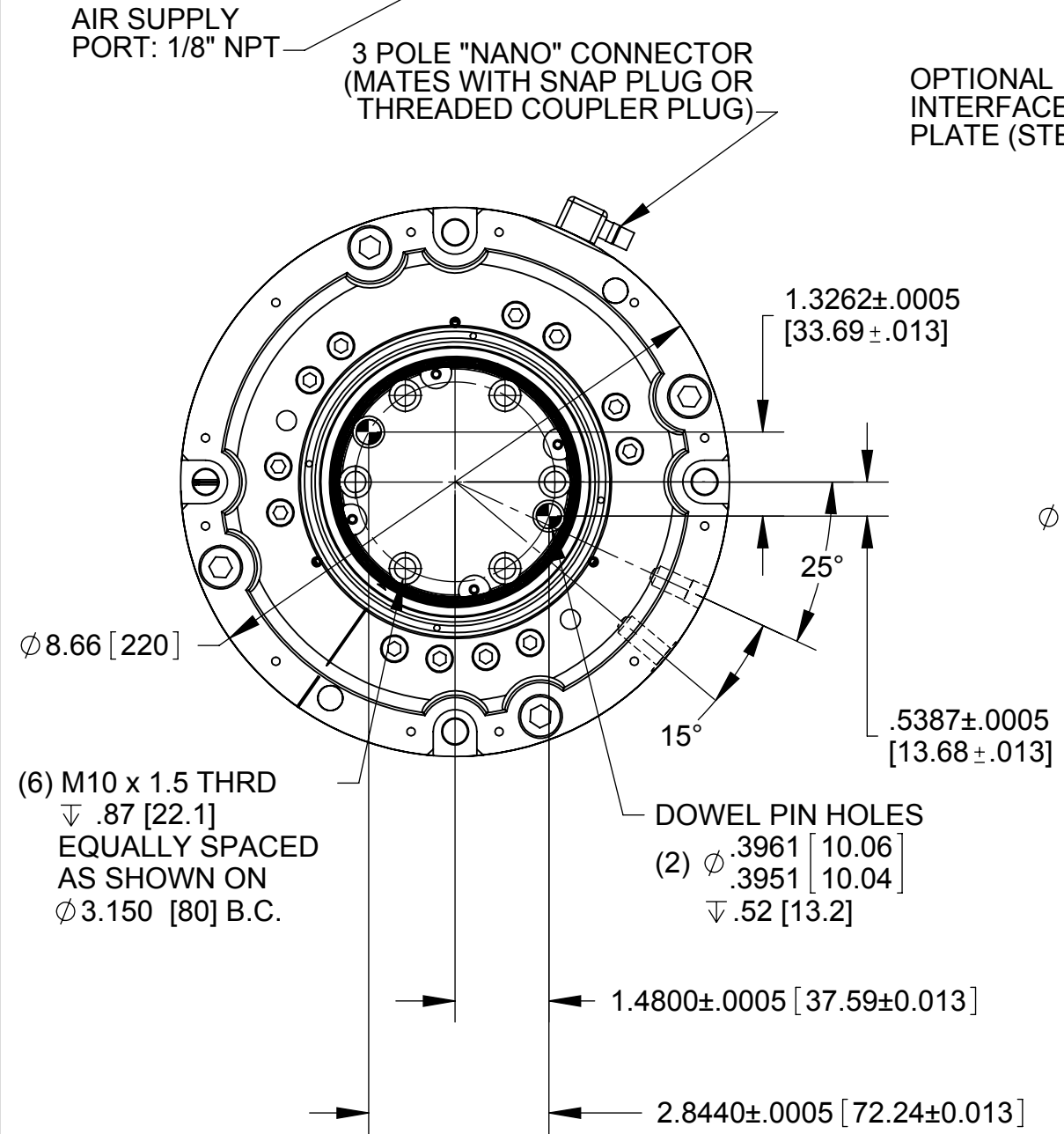

NOTES: UNLESS OTHERWISE SPECIFIED.

DO NOT SCALE DRAWING. ALL DIMENSIONS ARE IN INCHES.

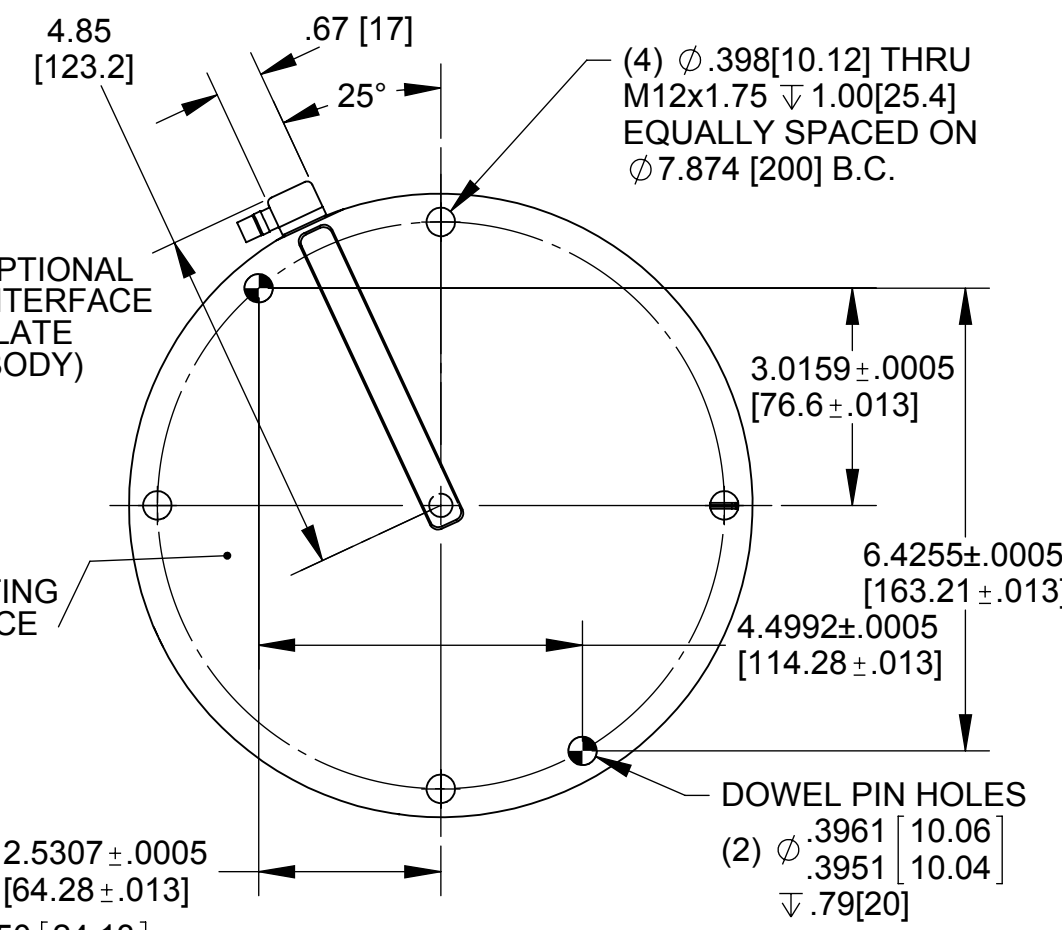
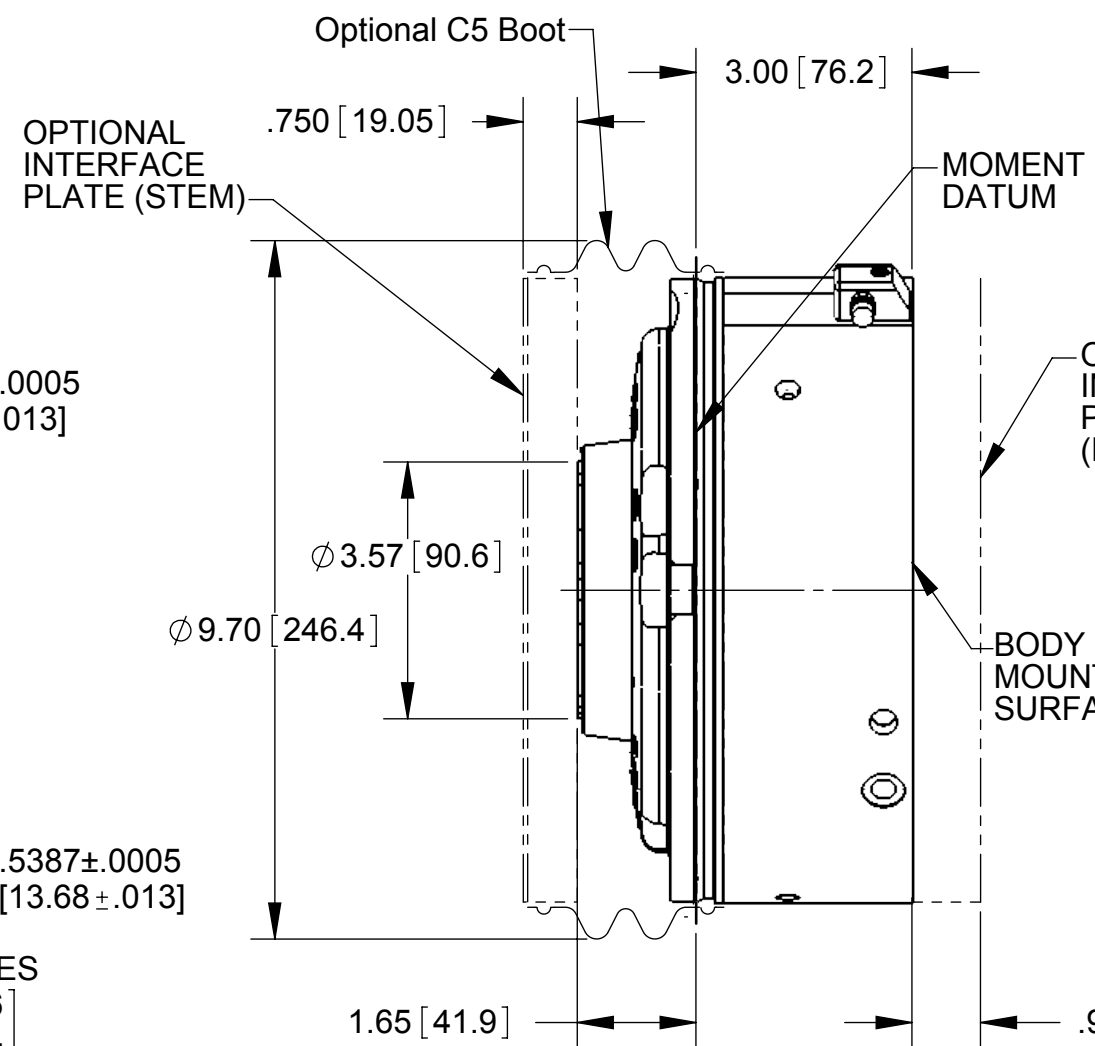
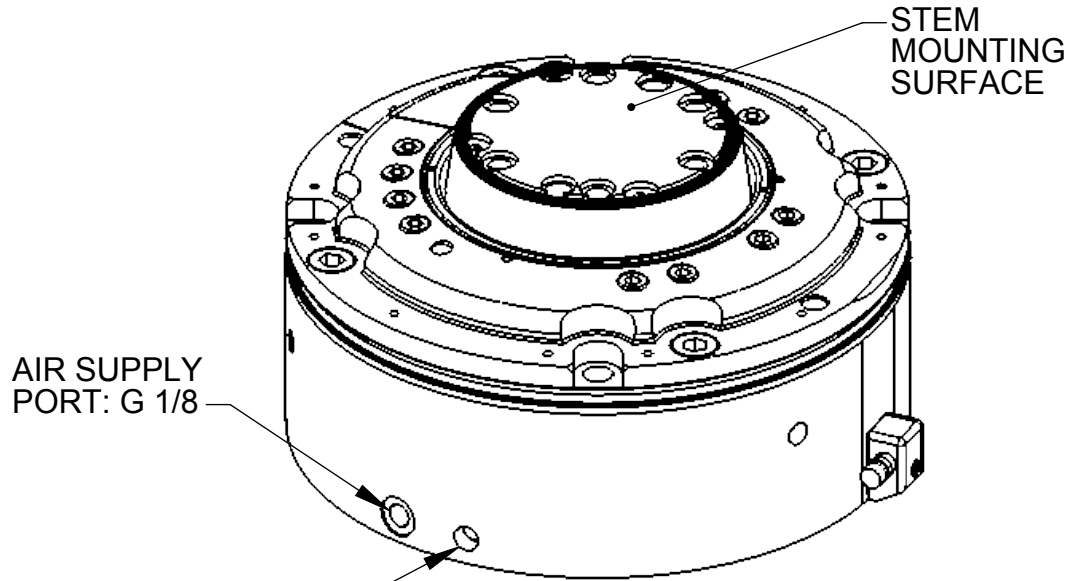
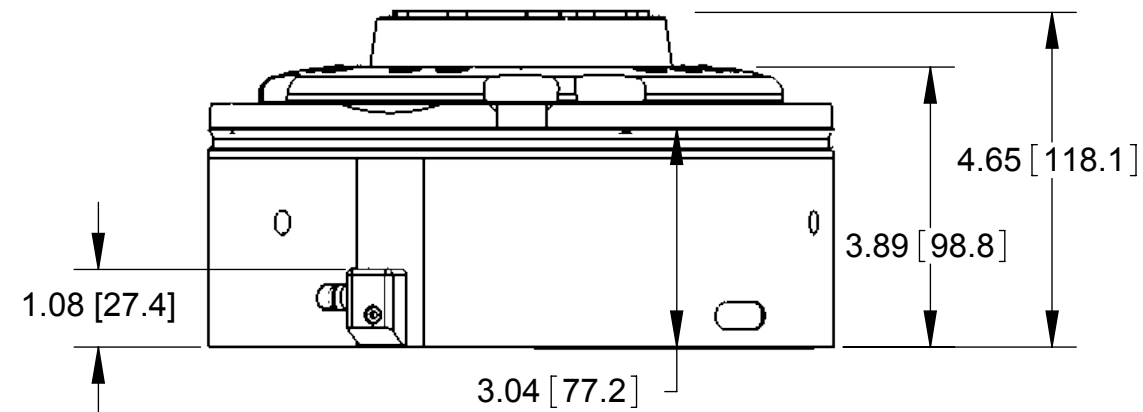
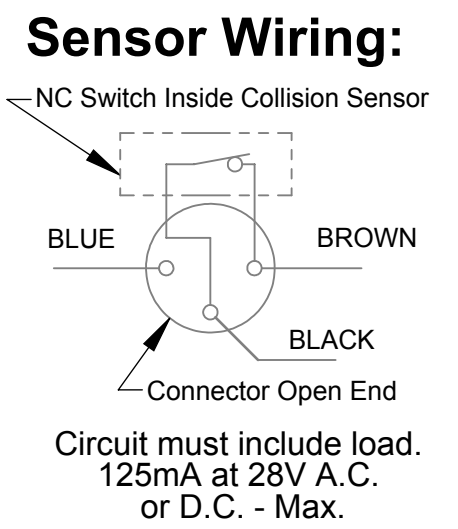
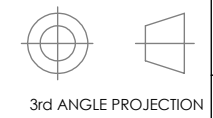

1031 Goodworth Drive, Apex, NC 27539, USA  
Tel: +1.919.772.0115 Email: info@ati-ia.com  
Fax: +1.919.772.8259 www.ati-ia.com  
ISO 9001 Registered Company

PROPERTY OF ATI INDUSTRIAL AUTOMATION, INC. NOT TO BE REPRODUCED IN ANY MANNER EXCEPT ON ORDER OR WITH PRIOR WRITTEN AUTHORIZATION OF ATI.

DRAWN BY: JFF 11-15-02		TITLE	
CHECKED BY: MLG 11-18-02		PROTECTOR, SR-221	
PROJECT # 010530-1	SHEET 1 OF 1	SCALE 3:8	SIZE B
		DRAWING NUMBER 9230-60-1034	REVISION 11