

Rev.	Description	Initiator	Date
13	Eco 16277; Updated sensor wiring diagram	LJH	11/20/17

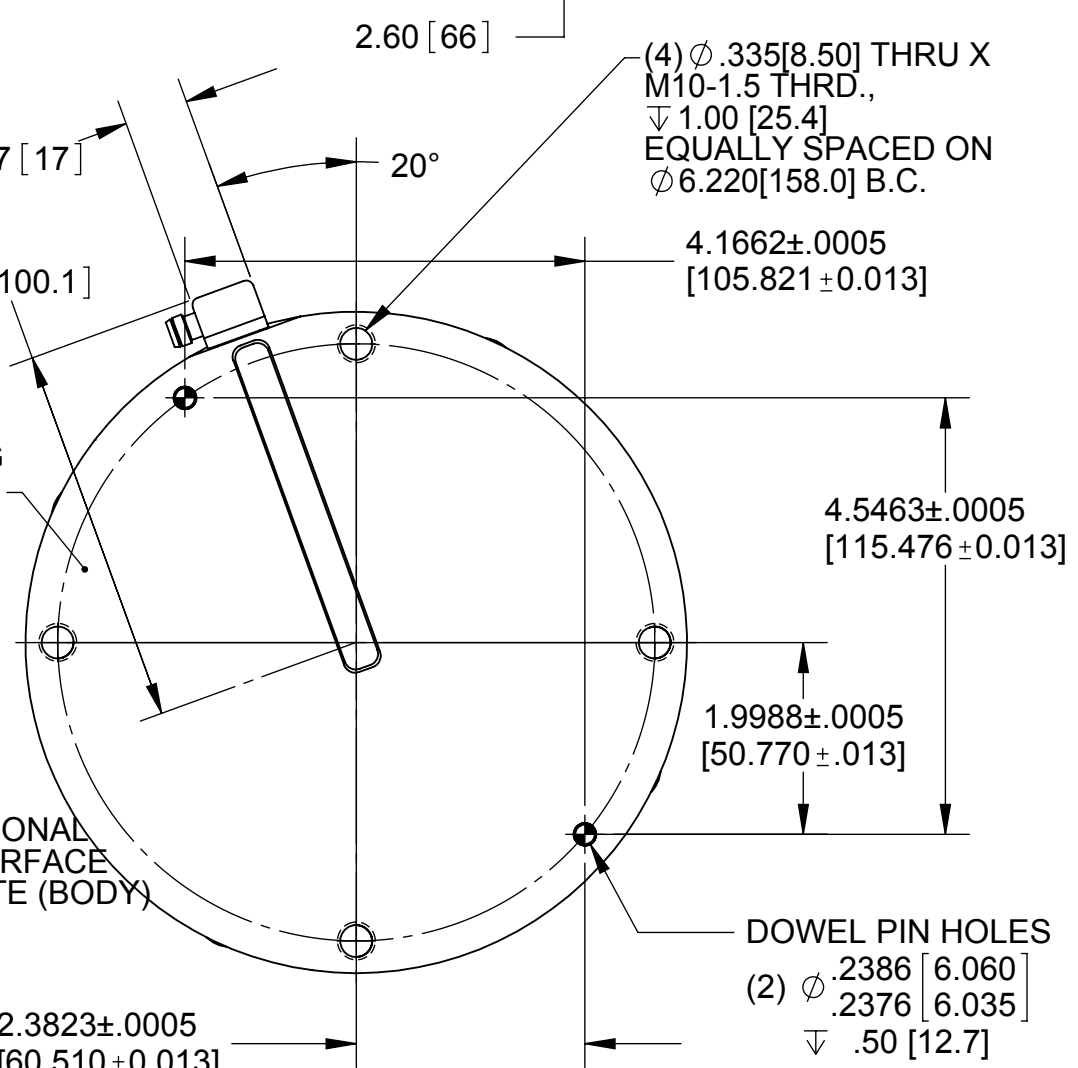
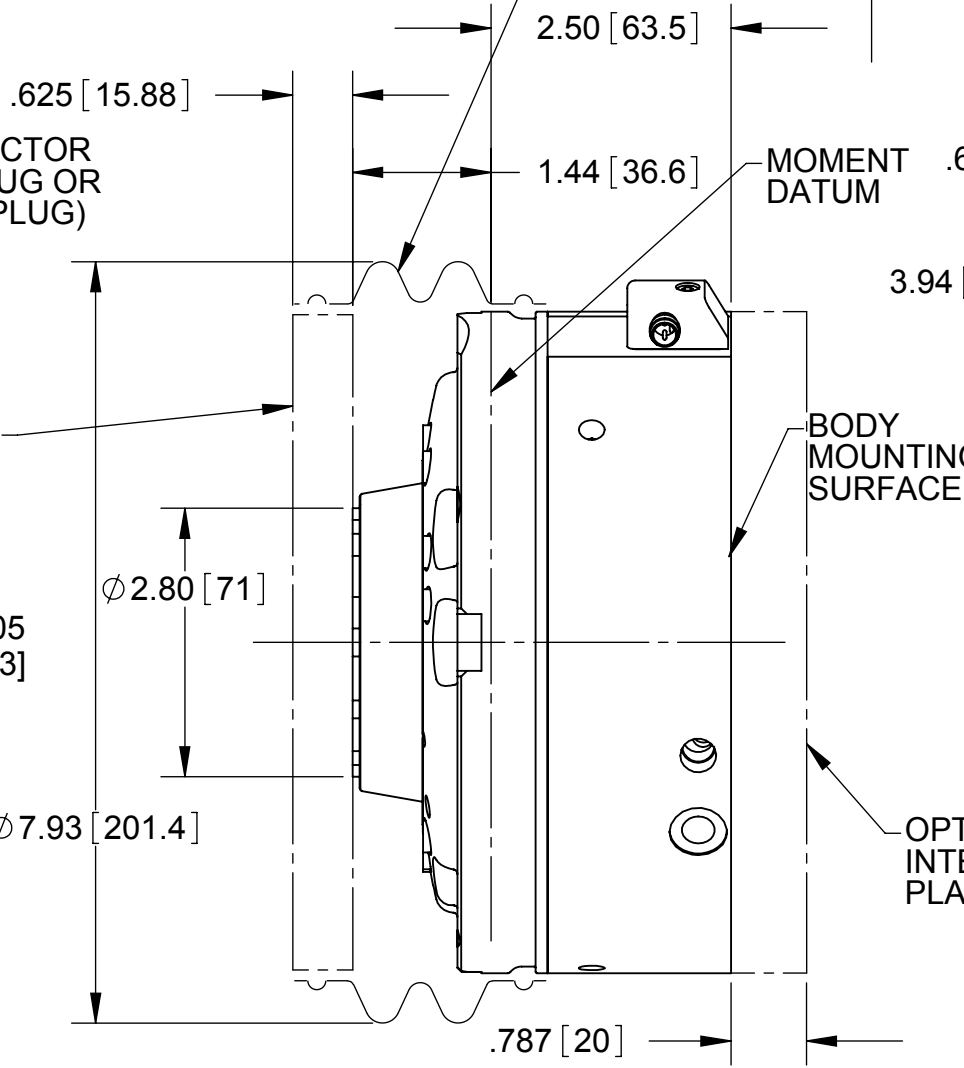
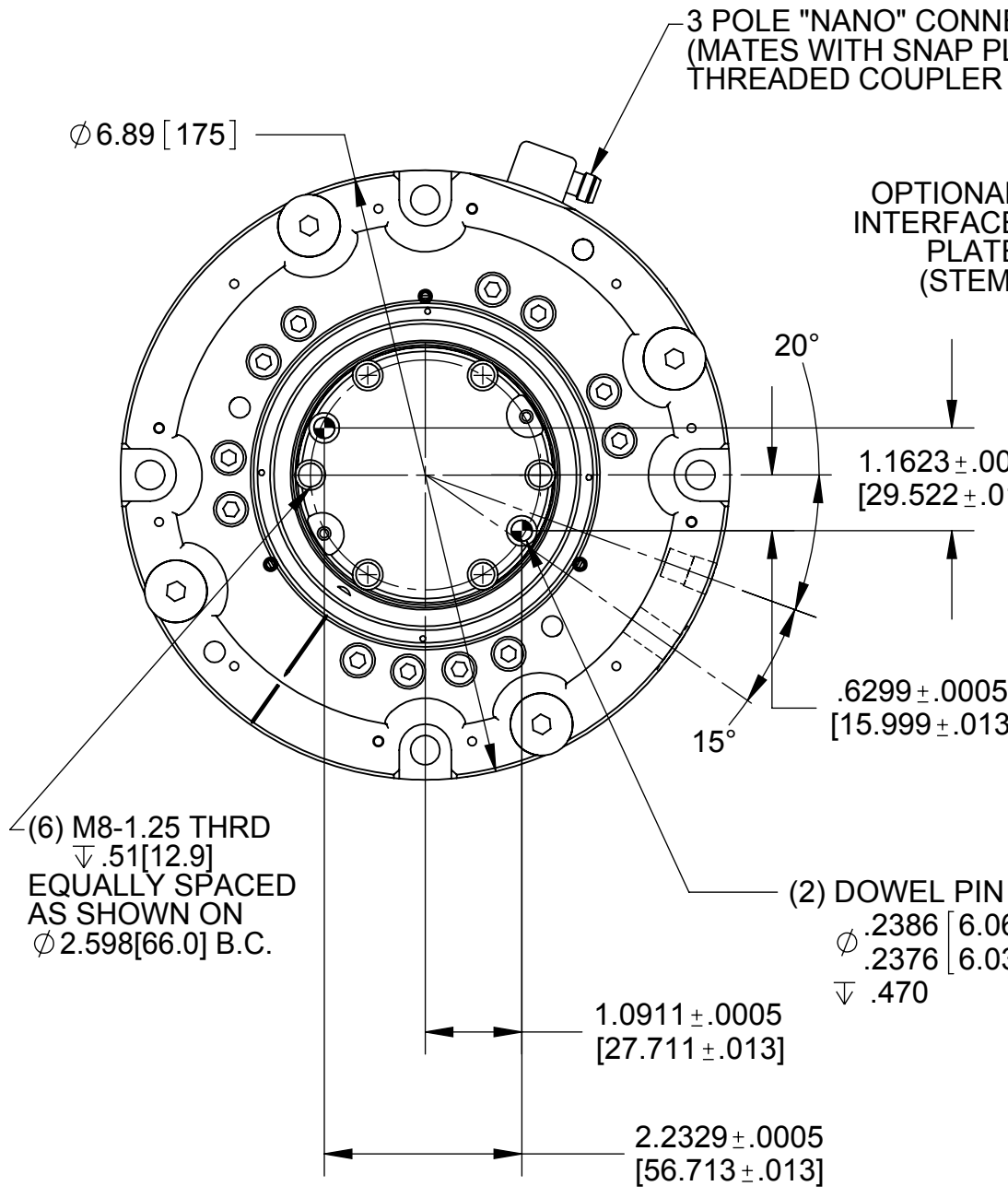
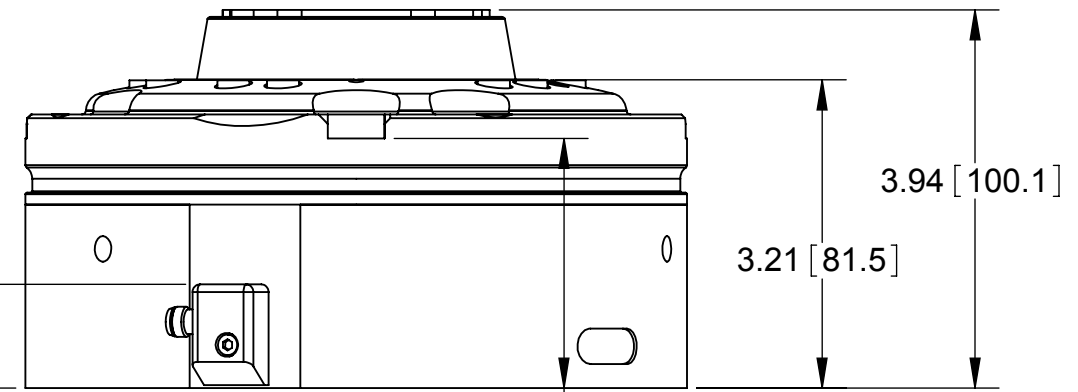
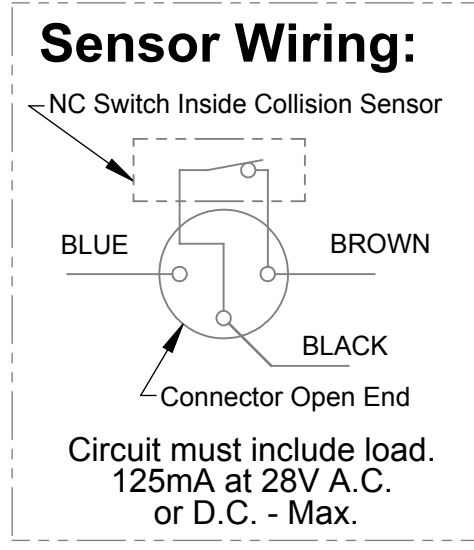
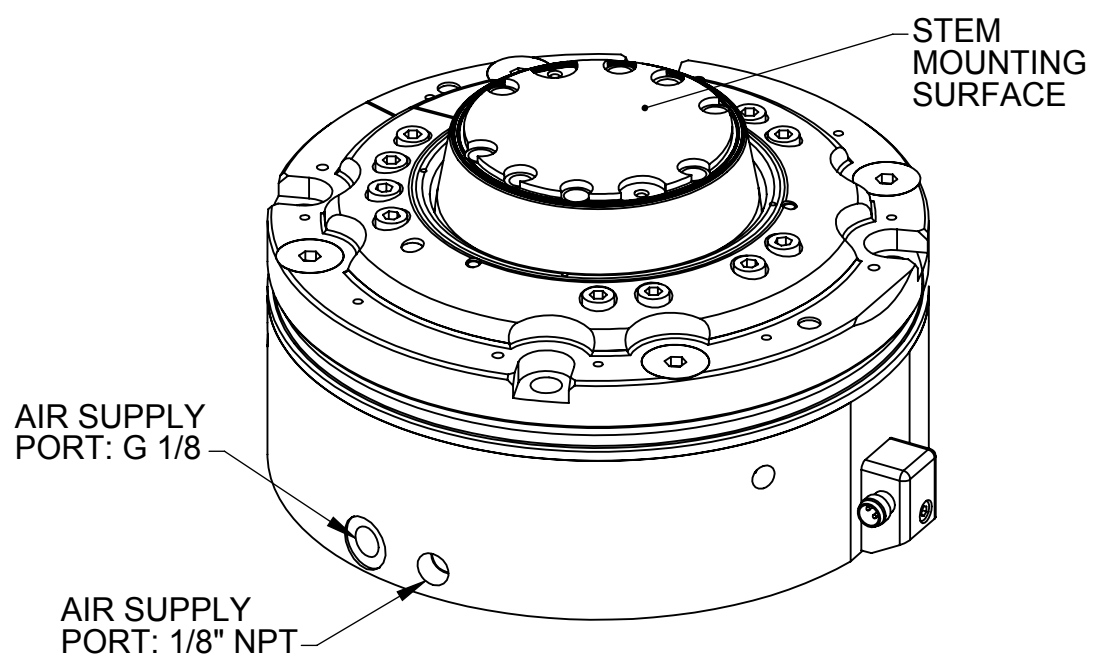

3 POLE "NANO" CONNECTOR
(MATES WITH SNAP PLUG OR
THREADED COUPLER PLUG)

OPTIONAL
INTERFACE
PLATE
(STEM)

BODY
MOUNTING
SURFACE

OPTIONAL
INTERFACE
PLATE (BODY)



NOTES: UNLESS OTHERWISE SPECIFIED.
DO NOT SCALE DRAWING.
ALL DIMENSIONS ARE IN INCHES.

1031 Goodworth Drive, Apex, NC 27539, USA
Tel: +1.919.772.0115 Email: info@ati-ia.com
Fax: +1.919.772.8259 www.ati-ia.com
ISO 9001 Registered Company

PROPERTY OF ATI INDUSTRIAL AUTOMATION, INC. NOT TO BE REPRODUCED IN ANY MANNER EXCEPT ON ORDER OR WITH PRIOR WRITTEN AUTHORIZATION OF ATI.

DRAWN BY: D. Wagner 3/12/02		TITLE	
CHECKED BY: MLG 11/12/02		PROTECTOR SR-176	
SCALE	SIZE	DRAWING NUMBER	REVISION
1:2	B	9230-60-1033	13

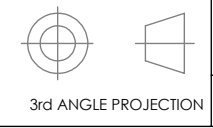

PROJECT # 010530-1 SHEET 1 OF 1