

Rev.	Description	Initiator	Date
12	ECO 16276: Updated wiring diagram to reflect use of 9160-CON-2.	TBC	12/19/2017

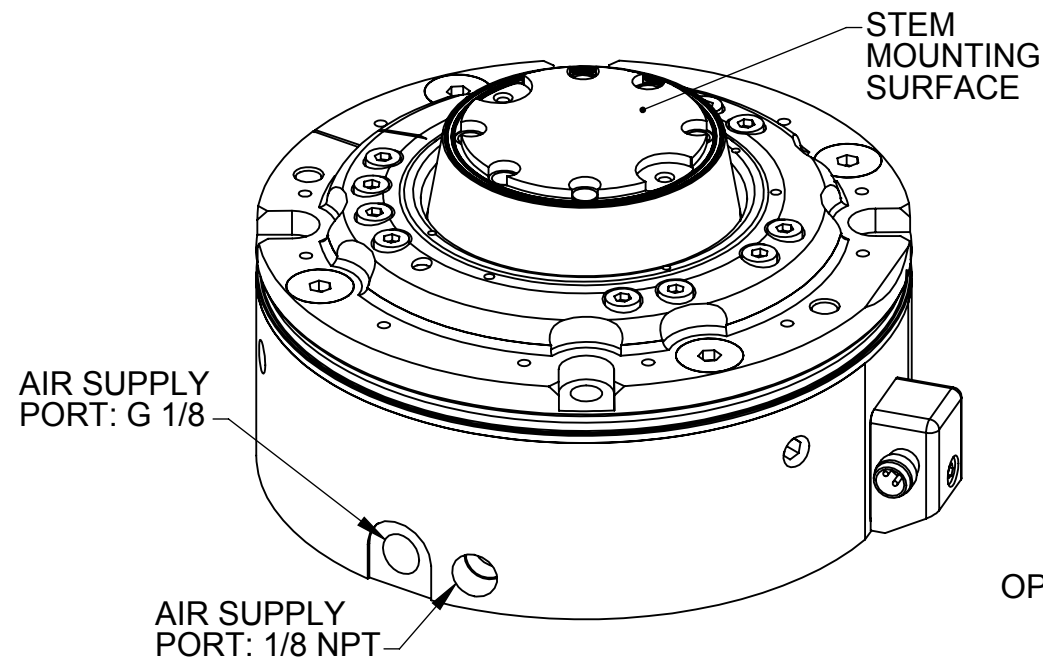

### Sensor Wiring:

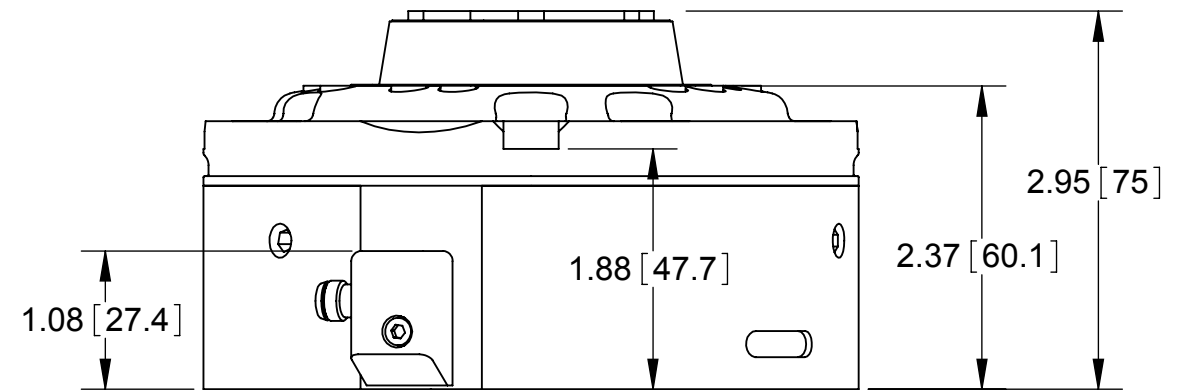
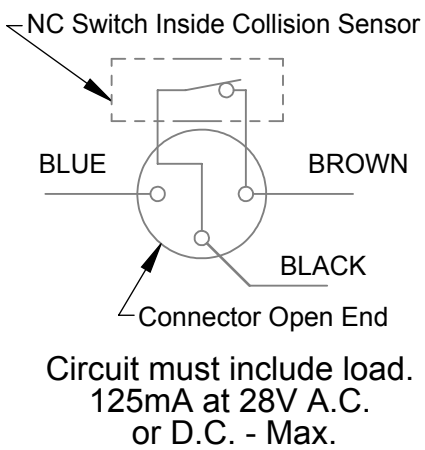

3 POLE "NANO" CONNECTOR  
(MATES WITH SNAP PLUG OR  
THREADED COUPLER PLUG)

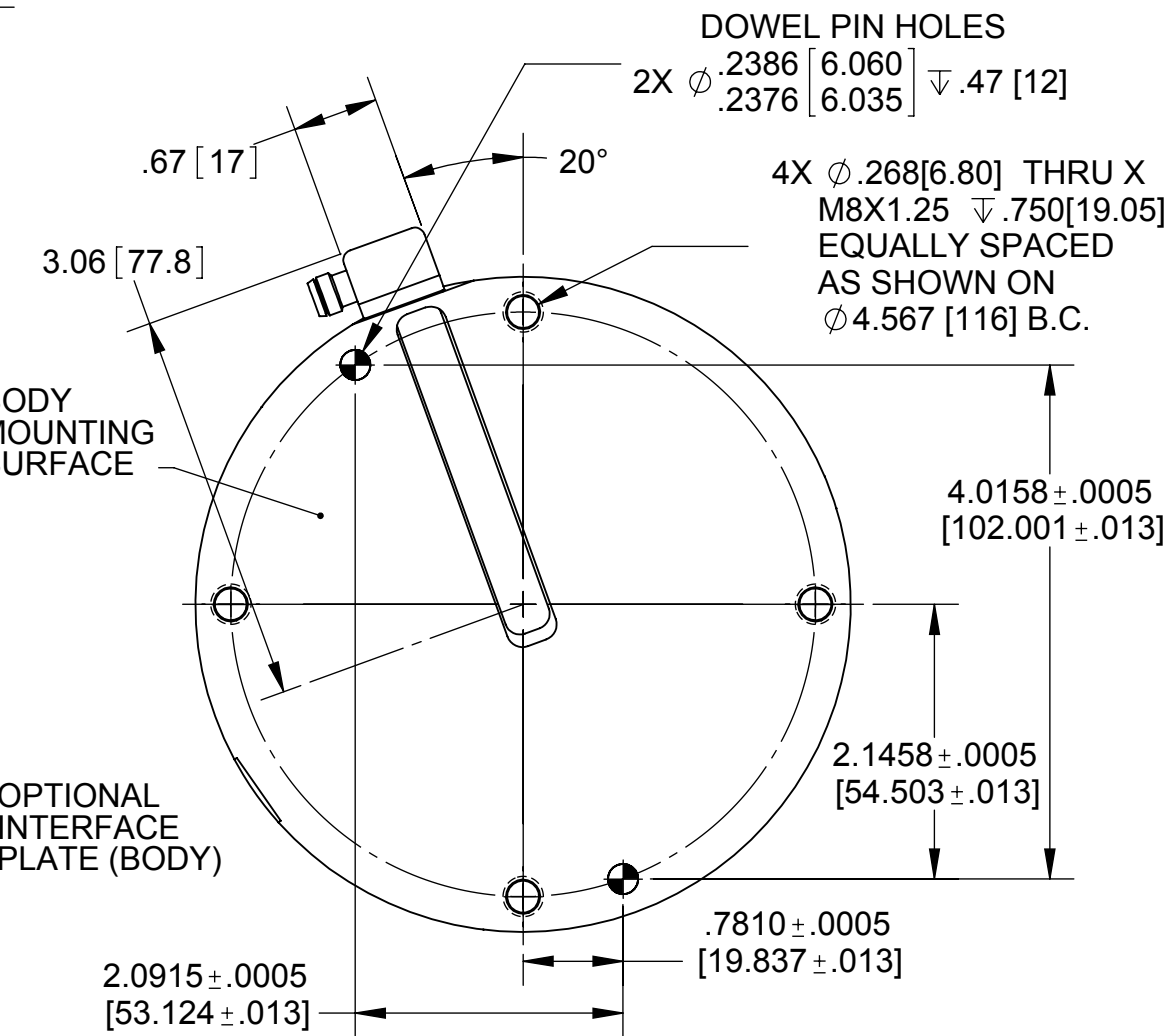
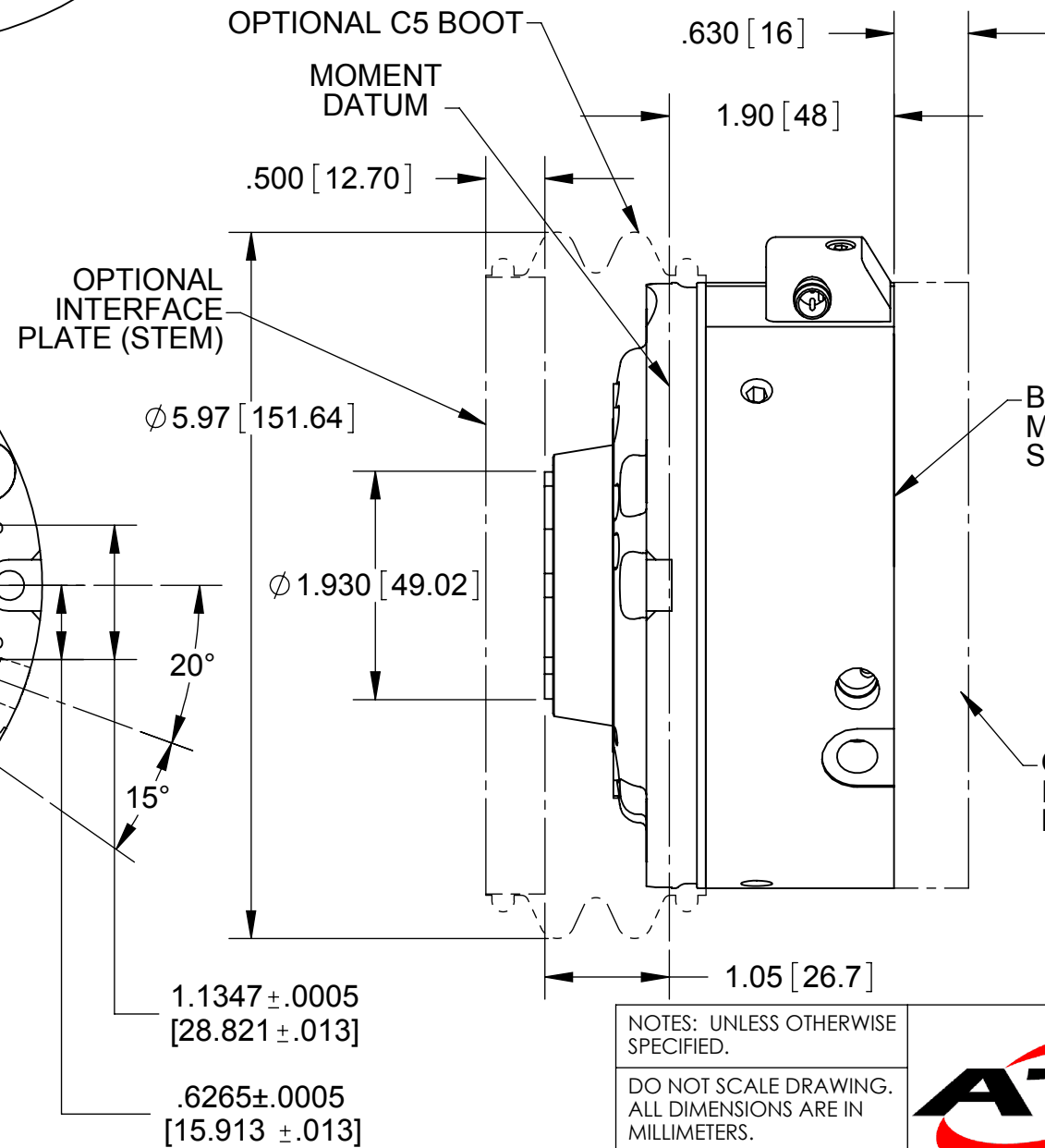
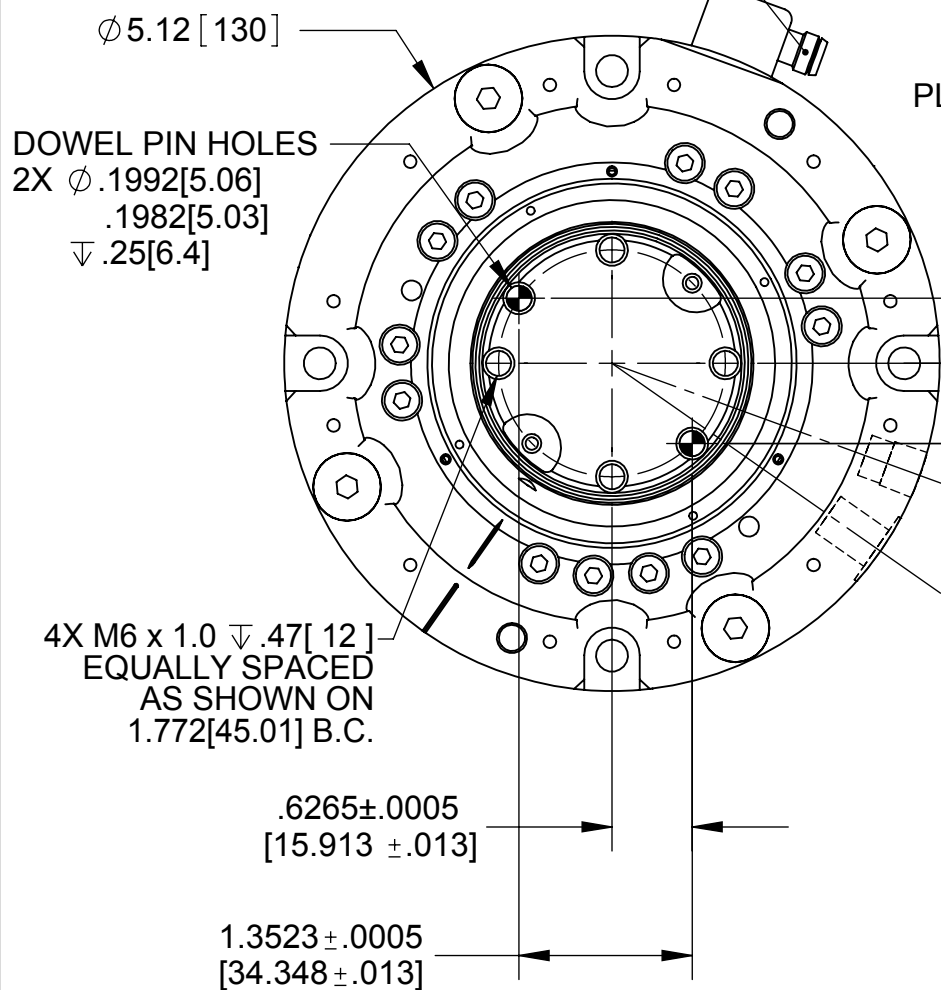

NOTES: UNLESS OTHERWISE SPECIFIED.

DO NOT SCALE DRAWING.  
ALL DIMENSIONS ARE IN  
MILLIMETERS.

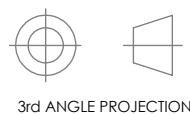

1031 Goodworth Drive, Apex, NC 27539, USA  
Tel: +1.919.772.0115 Email: info@ati-ia.com  
Fax: +1.919.772.8259 www.ati-ia.com  
ISO 9001 Registered Company

PROPERTY OF ATI INDUSTRIAL AUTOMATION, INC. NOT TO BE REPRODUCED IN ANY MANNER EXCEPT ON ORDER OR WITH PRIOR WRITTEN AUTHORIZATION OF ATI.

DRAWN BY: JFF 08/26/02		TITLE	
CHECKED BY: MLG 11-11-02		SR-131 ASSY	
SCALE	SIZE	DRAWING NUMBER	REVISION
1:1.5	B	9230-60-1032	12
PROJECT # 010530-1 SHEET 1 OF 1			