

Rev.	Description	Initiator	Date
07	Added optional IPB	LJH	3/16/2004
08	M6-1 was .34 [7.4]dp	LJH	5/3/2004

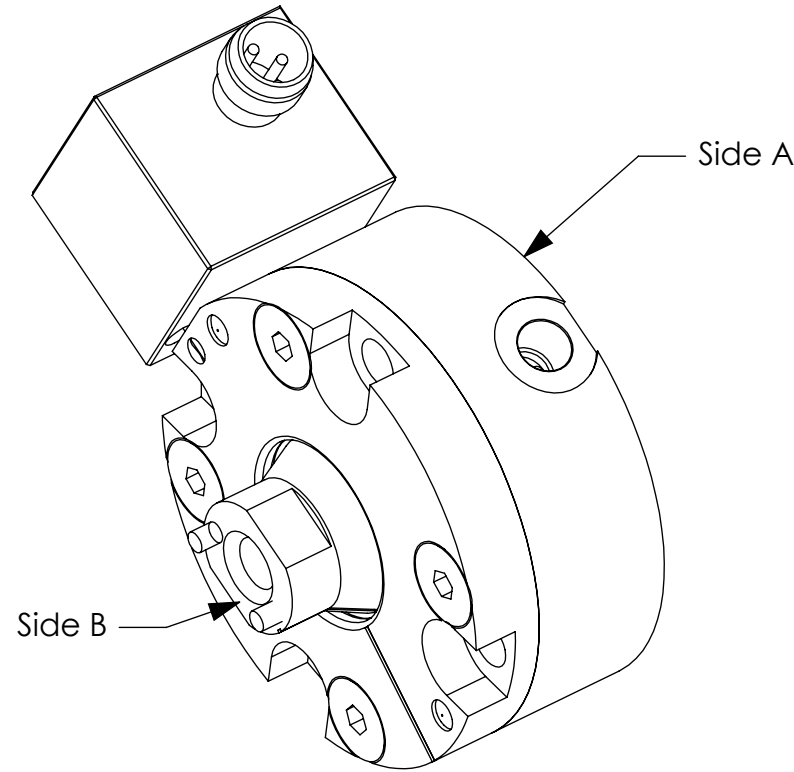

### Sensor Wiring

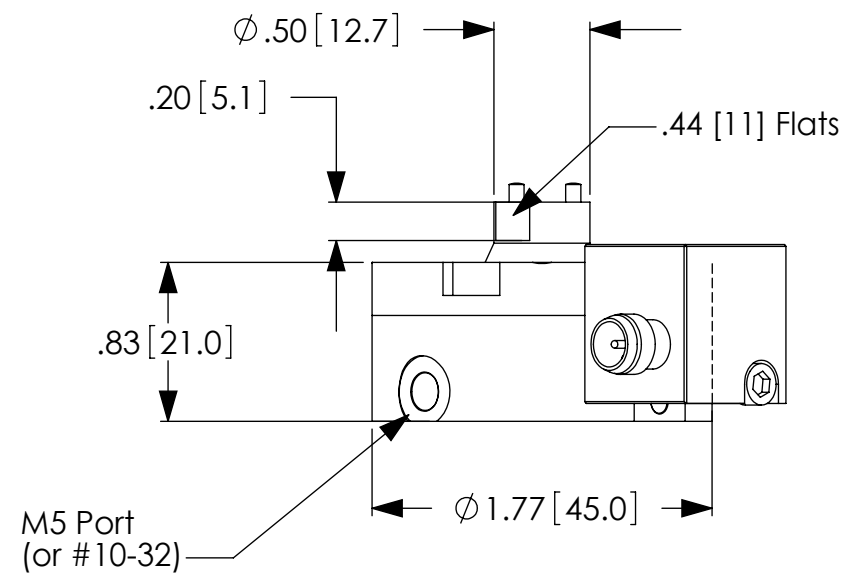
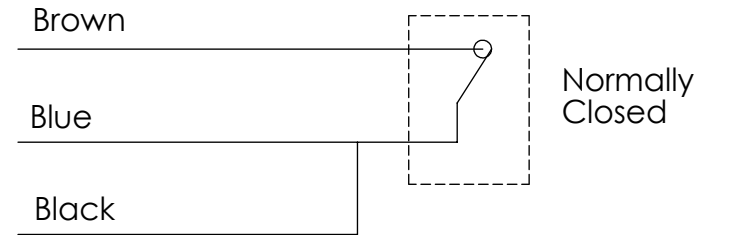

**MUST ATTACH LOAD BEFORE VOLTAGE IS APPLIED**

Notes:  
 1) 125mA at 28V A.C or D.C - Maximums

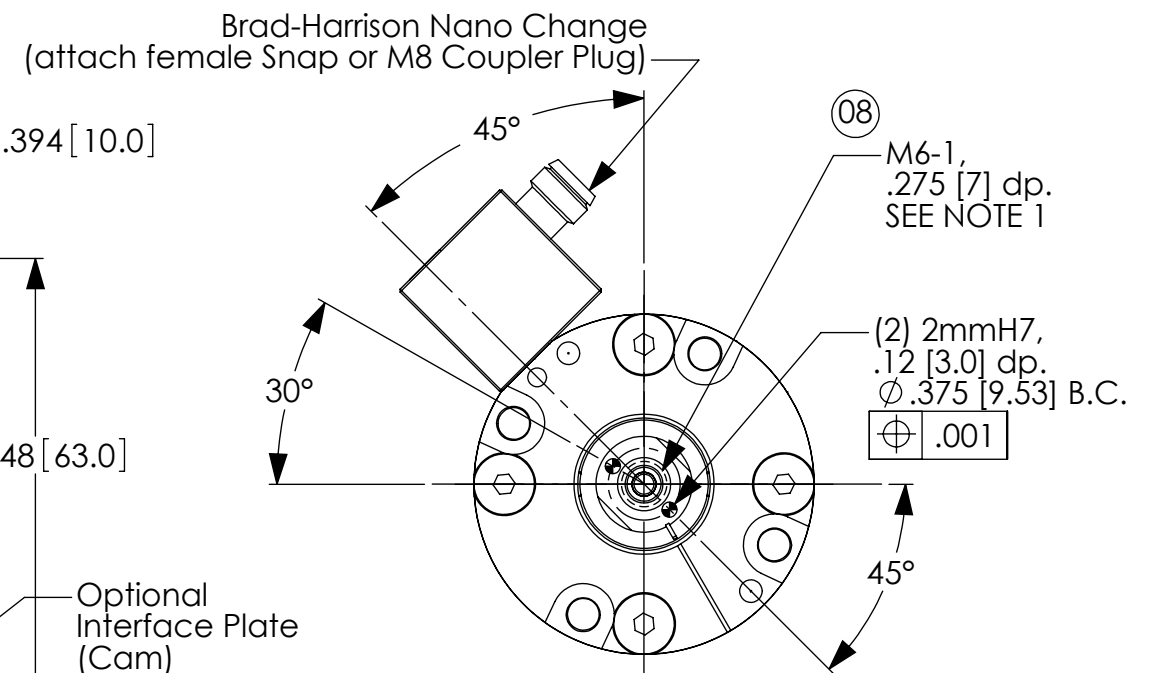
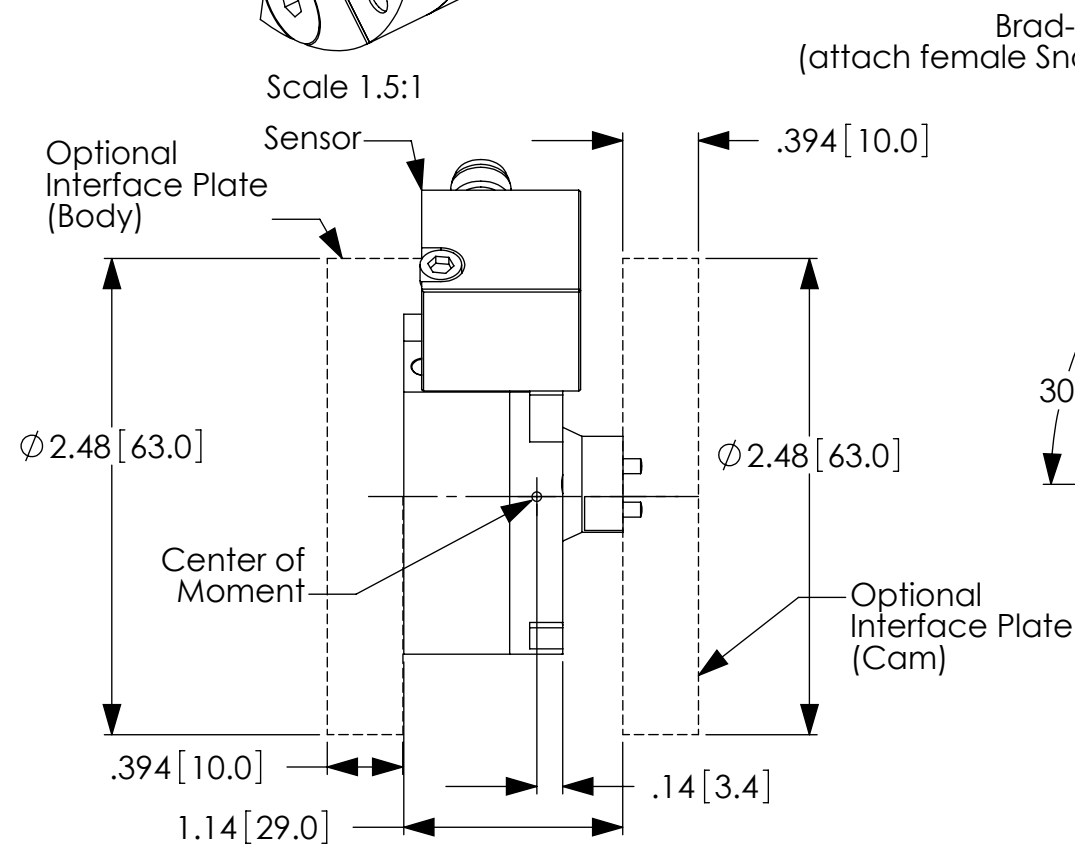
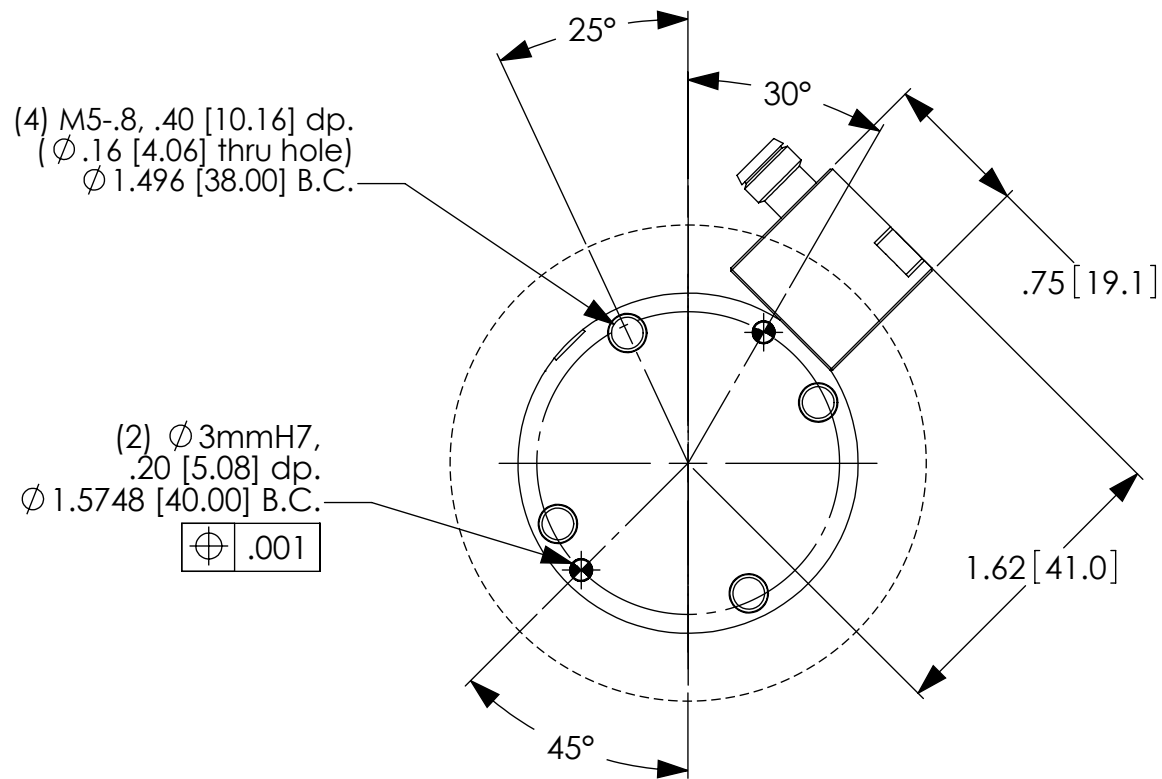

NOTES: UNLESS OTHERWISE SPECIFIED  
 DO NOT SCALE DRAWING. DRAWN IN SOLIDWORKS.  
 ALL DIMENSIONS ARE IN MILLIMETERS.



1031 Goodworth Drive, Apex, NC 27539, USA  
 Tel: +1.919.772.0115 Email: info@ati-ia.com  
 Fax: +1.919.772.8259 www.ati-ia.com  
 ISO 9001 Registered Company

NOTES:  
 1. MATING FASTENER MUST NOT THREAD INTO CAM BEYOND STATED DEPTH OF THREADS.

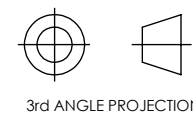

DRAWN BY: P.B 06/11/99	TITLE: PROTECTOR SR-45		
CHECKED BY: DAW 3/16/04	SCALE: 1:1	SIZE: B	DRAWING NUMBER: 9230-60-1005-08
WEIGHT LBS:	PRODUCT RELEASE #	DATE:	SHEET 1 OF 1
ASSEMBLY REF:			