

PROFILE FOLLOWER TIP INSTALLATION

REV.	DESCRIPTION	INITIATOR	DATE
01	INITIAL RELEASE	BRR	8/22/2019

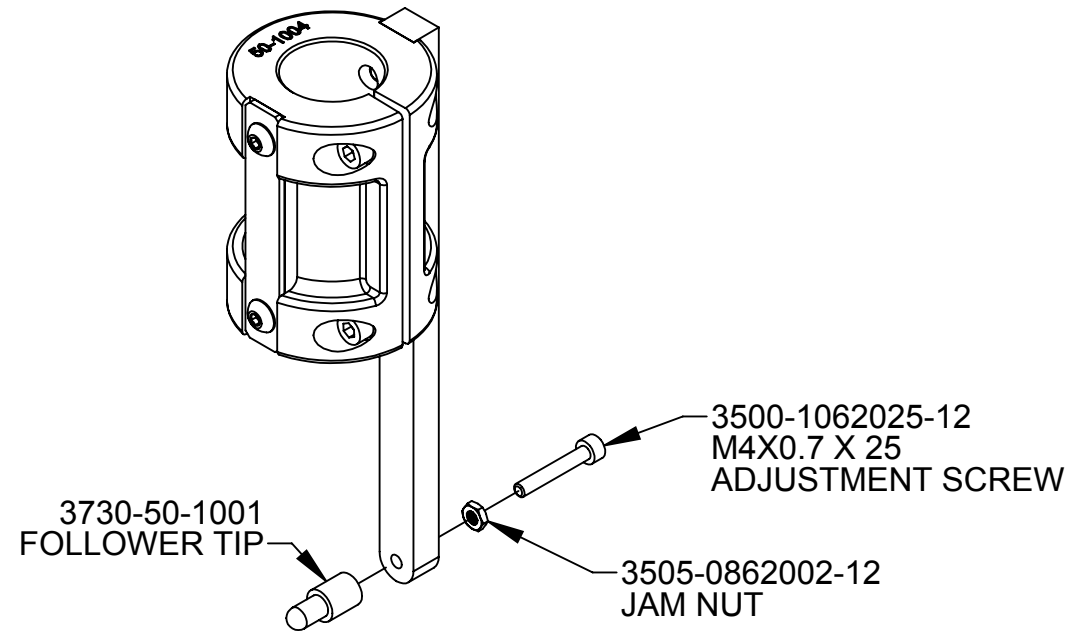

A PROFILE FOLLOWER TIP, JAM NUT, AND ADJUSTMENT SCREW ARE SHIPPED LOOSE WITH THE UNIT. ANY GEOMETRY FOLLOWER TIP CAN BE USED AS LONG AS AN M4X0.7 THREADED INTERFACE IS AVAILABLE.

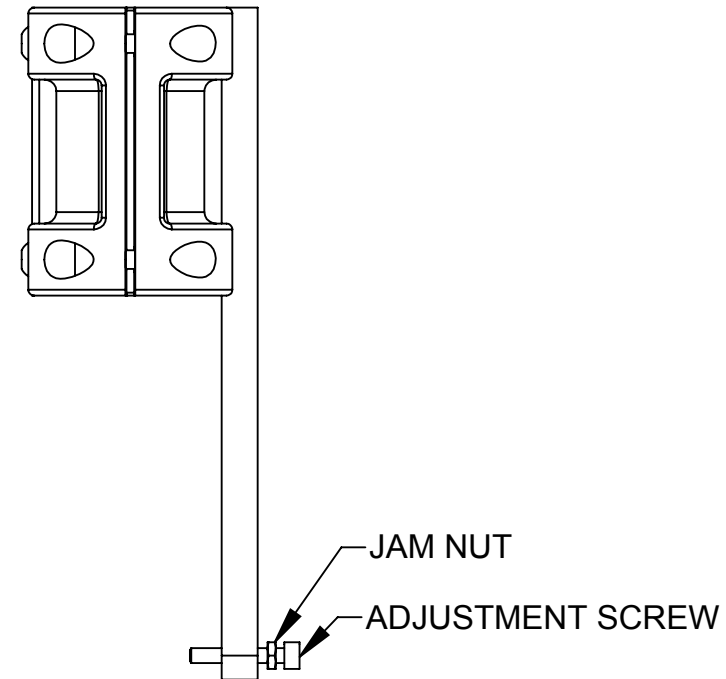

STEP 1: TO INSTALL THE SUPPLIED PROFILE FOLLOWER TIP, THREAD THE JAM NUT ONTO THE ADJUSTMENT SCREW.
STEP 2: THEN THREAD THE ADJUSTMENT SCREW THROUGH THE ARM OF THE PROFILE FOLLOWER.

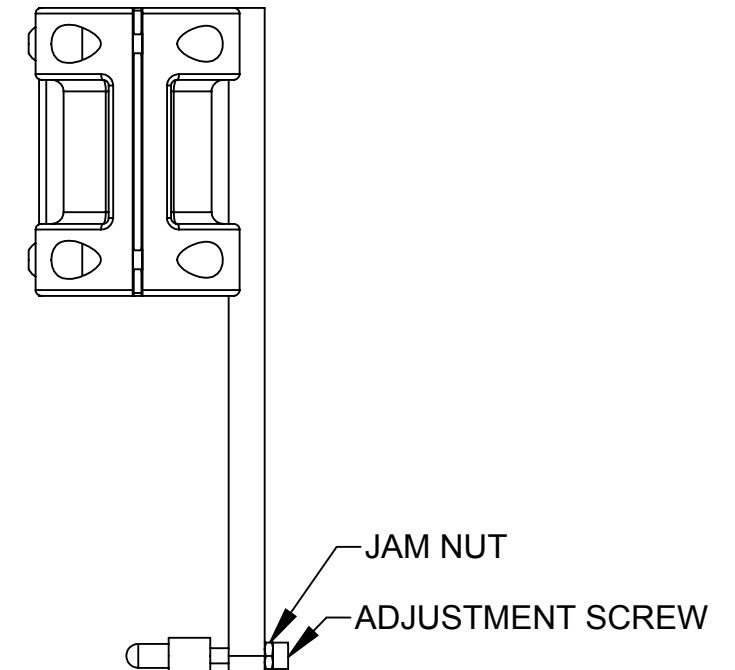

STEP 3: APPLY LOCTITE 222 OR EQUIVALENT TO THE INTERNAL THREADS OF THE FOLLOWER TIP AND THREAD THE TIP ONTO THE END OF THE ADJUSTMENT SCREW. TIGHTEN UNTIL SCREW BOTTOMS OUT IN TIP.

PROFILE FOLLOWER TIP ADJUSTMENT

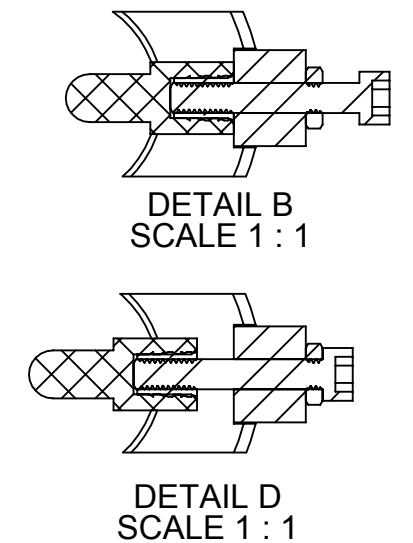
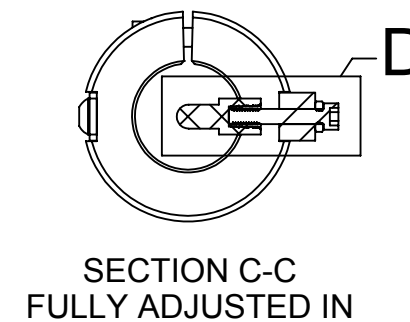
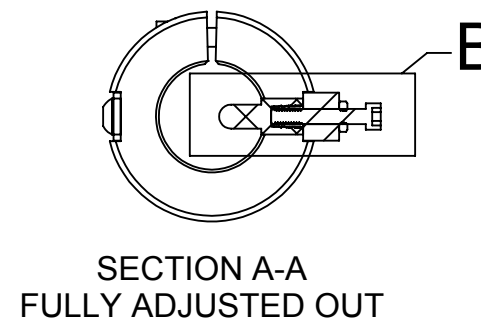
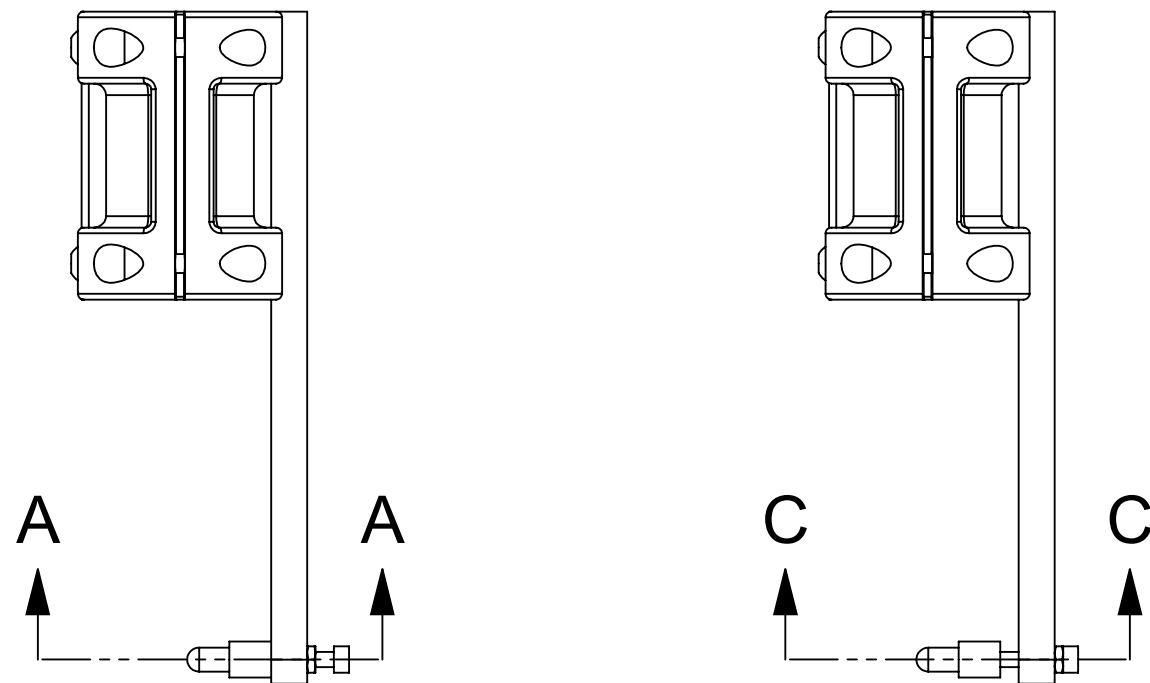

STEP 1: THREAD THE ADJUSTMENT SCREW TO DESIRED POSITION.
STEP 2: ONCE IN DESIRED POSITION, TIGHTEN JAM NUT AGAINST PROFILE FOLLOWER ARM.

NOTES: UNLESS OTHERWISE SPECIFIED.

DO NOT SCALE DRAWING. ALL DIMENSIONS ARE IN MILLIMETERS.

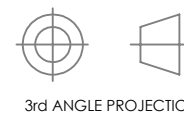

1031 Goodworth Drive, Apex, NC 27539, USA
 Tel: +1.919.772.0115 www.ati-ia.com
 Fax: +1.919.772.8259 ISO 9001 Registered Company

PROPERTY OF ATI INDUSTRIAL AUTOMATION, INC. NOT TO BE REPRODUCED IN ANY MANNER EXCEPT ON ORDER OR WITH PRIOR WRITTEN AUTHORIZATION OF ATI.

DRAWN BY: B. Rose - 8/22/2019		TITLE	
CHECKED BY: D. Bohle - 8/22/2019		PF2 Profile Follower Instruction Drawing	
PROJECT # 180507-1	SHEET 1 OF 3	SCALE 1:2	SIZE B
		DRAWING NUMBER 9230-50-1082	REVISION 01

PROFILE FOLLOWER INSTALLATION

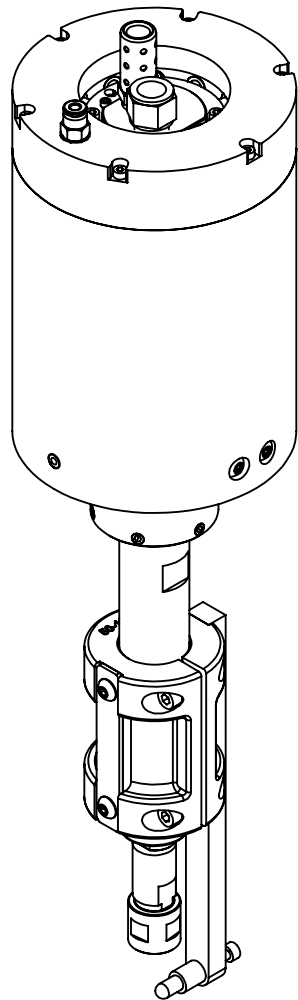

INSTALLATION ON RCV-390
INSTALLATION INSTRUCTIONS APPLY
TO ALL RCV-390 MODELS

CLAMP SCREWS

STEP 1: LOOSEN THE TWO M5 CLAMP
SCREWS TO ALLOW THE CLAMP TO OPEN.

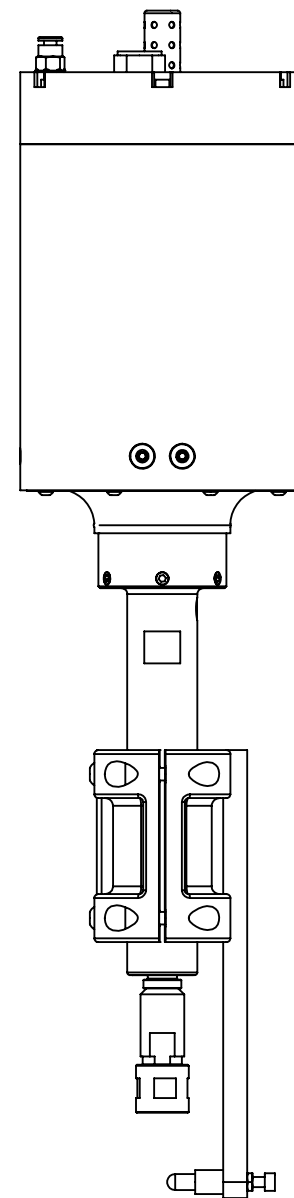
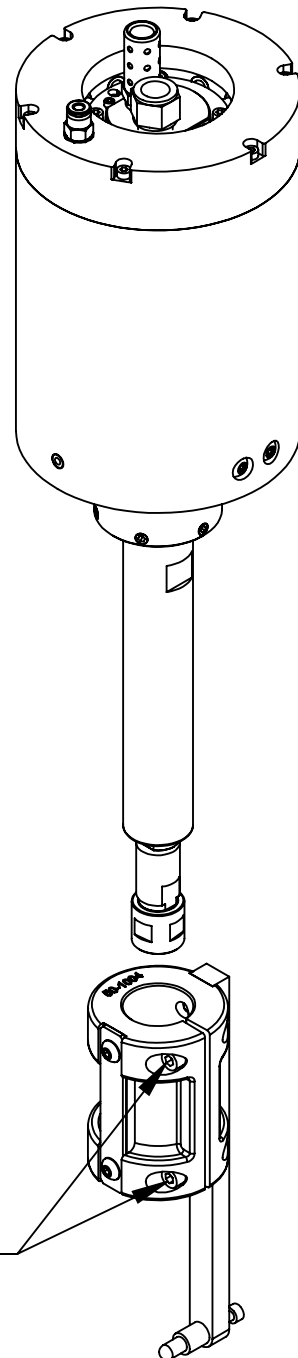

STEP 2: INSTALL PROFILE FOLLOWER
ONTO SPINDLE OF TOOL.
STEP 3: ONCE IN DESIRED LOCATION,
TIGHTEN M5 CLAMP SCREWS TO 6IN-LBS

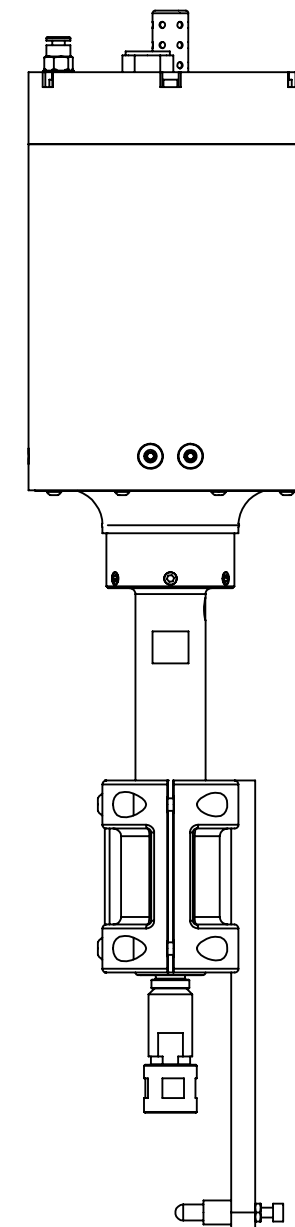

PROFILE FOLLOWER SHOWN IN LOWEST
PERMISSIBLE LOCATION. PROFILE FOLLOWER
NOT TO OVERHANG END OF SPINDLE.

NOTES: UNLESS OTHERWISE
SPECIFIED.

DO NOT SCALE DRAWING.
ALL DIMENSIONS ARE IN
MILLIMETERS.



3rd ANGLE PROJECTION



1031 Goodworth Drive, Apex, NC 27539, USA
Tel: +1.919.772.0115 www.ati-ia.com
Fax: +1.919.772.8259 ISO 9001 Registered Company

PROPERTY OF ATI INDUSTRIAL AUTOMATION, INC. NOT TO BE REPRODUCED IN ANY
MANNER EXCEPT ON ORDER OR WITH PRIOR WRITTEN AUTHORIZATION OF ATI.

DRAWN BY: B. Rose - 8/22/2019

CHECKED BY: D. Bohle - 8/22/2019

PROJECT # 180507-1 SHEET 2 OF 3

TITLE

PF2 Profile Follower Instruction Drawing

SCALE
1:3

SIZE
B

DRAWING NUMBER
9230-50-1082

REVISION
01

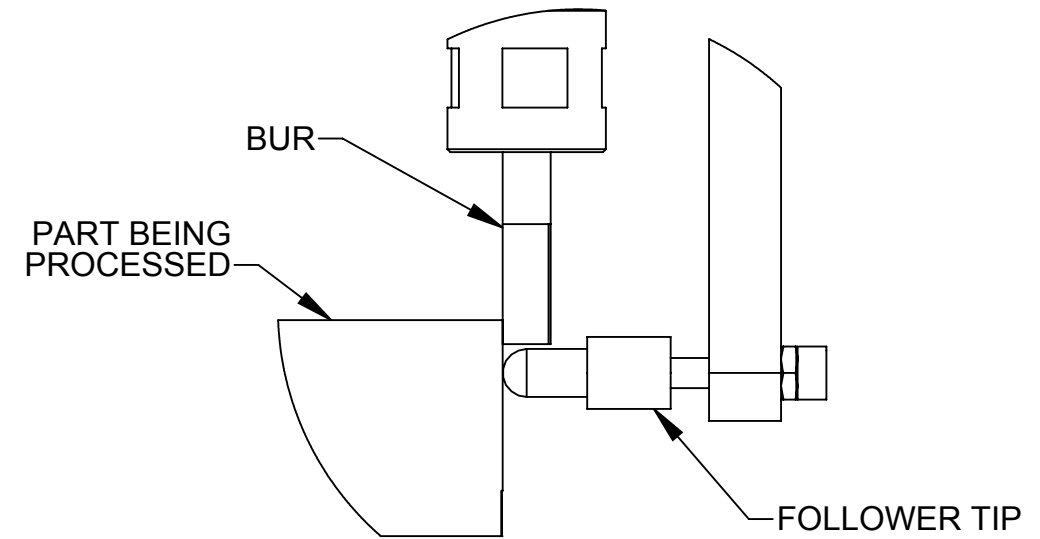
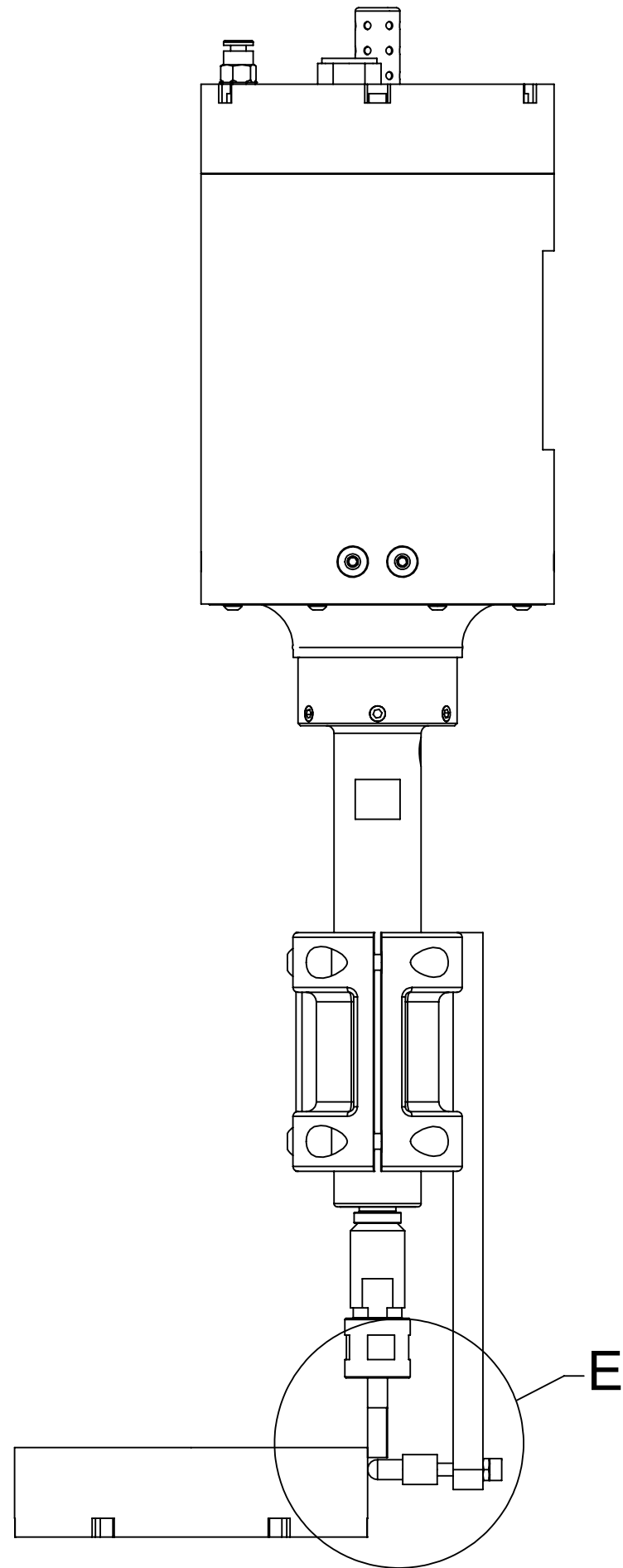

DETAIL E
SCALE 1 : 1

PROFILE FOLLOWER TIP FOLLOWS THE PROFILE OF THE
PART PREVENTING POTENTIAL OF BURR GOUGING THE PART

NOTES: UNLESS OTHERWISE SPECIFIED.

DO NOT SCALE DRAWING.
ALL DIMENSIONS ARE IN
MILLIMETERS.



3rd ANGLE PROJECTION



1031 Goodworth Drive, Apex, NC 27539, USA
Tel: +1.919.772.0115 www.ati-ia.com
Fax: +1.919.772.8259 ISO 9001 Registered Company

PROPERTY OF ATI INDUSTRIAL AUTOMATION, INC. NOT TO BE REPRODUCED IN ANY MANNER EXCEPT ON ORDER OR WITH PRIOR WRITTEN AUTHORIZATION OF ATI.

DRAWN BY: B. Rose - 8/22/2019

CHECKED BY: D. Bohle - 8/22/2019

PROJECT # 180507-1 SHEET 3 OF 3

TITLE
PF2 Profile Follower Instruction Drawing

SCALE	SIZE	DRAWING NUMBER	REVISION
1:2	B	9230-50-1082	01