

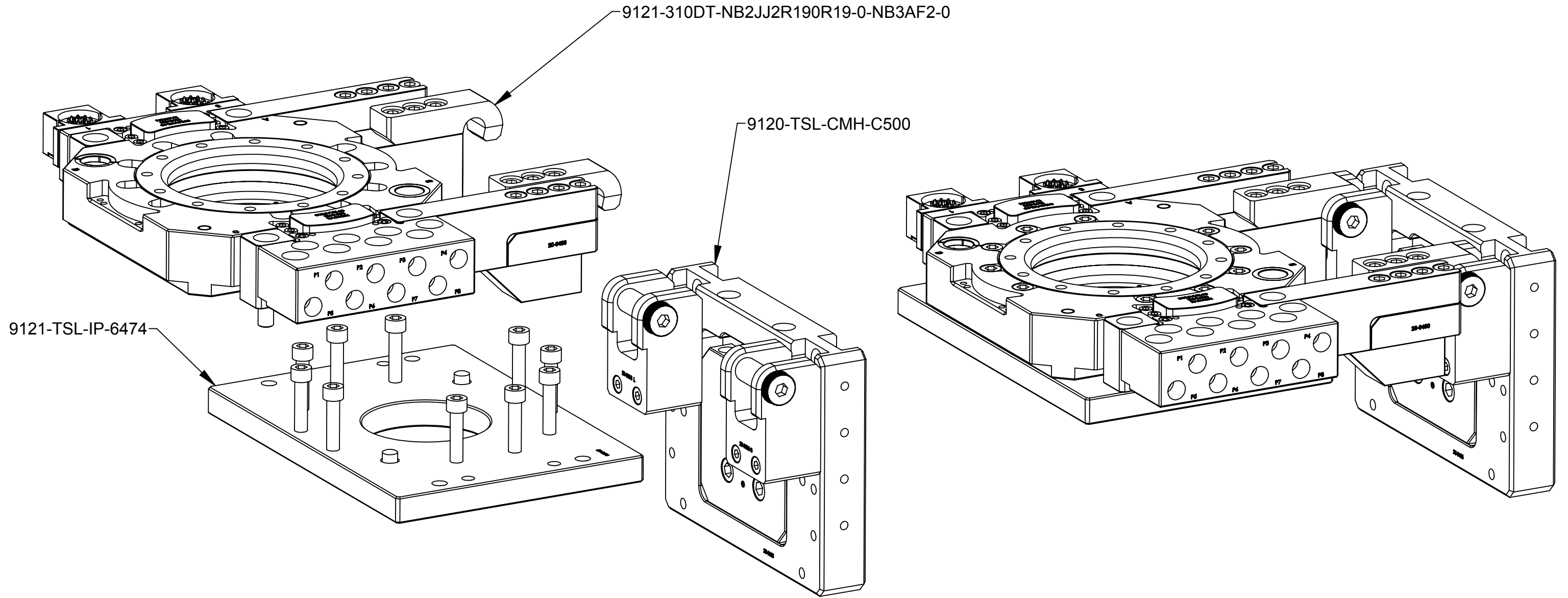

Rev.	Description	Initiator	Date
04	Eco 14668: Updated to show thicker ledge cleat.	LJH	7/27/16

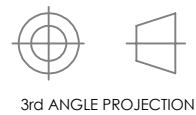

NOTES: UNLESS OTHERWISE SPECIFIED.

DO NOT SCALE DRAWING. ALL DIMENSIONS ARE IN MILLIMETERS.



		1031 Goodworth Drive, Apex, NC 27539, USA Tel: +1.919.772.0115 Email: info@ati-ia.com Fax: +1.919.772.8259 www.ati-ia.com ISO 9001 Registered Company	
		PROPERTY OF ATI INDUSTRIAL AUTOMATION, INC. NOT TO BE REPRODUCED IN ANY MANNER EXCEPT ON ORDER OR WITH PRIOR WRITTEN AUTHORIZATION OF ATI.	
DRAWN BY: K Potts 6/21/10 CHECKED BY: D Norton 6/21/10		TITLE Large Tool Stand Assemblies, Hook-style, QC310	
PROJECT # 100615-1 SHEET 1 OF 3	SCALE 1:3	SIZE B	DRAWING NUMBER 9230-20-3231
			REVISION 04

Rev.	Description	Initiator	Date
-	See Sheet1	-	-

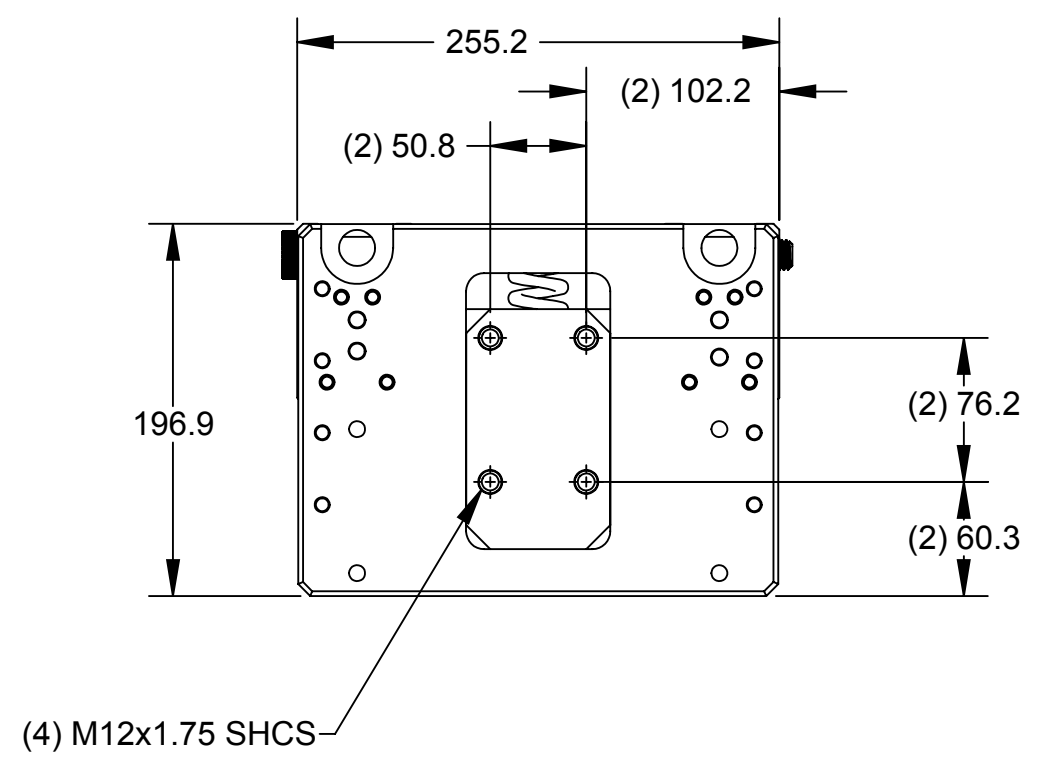
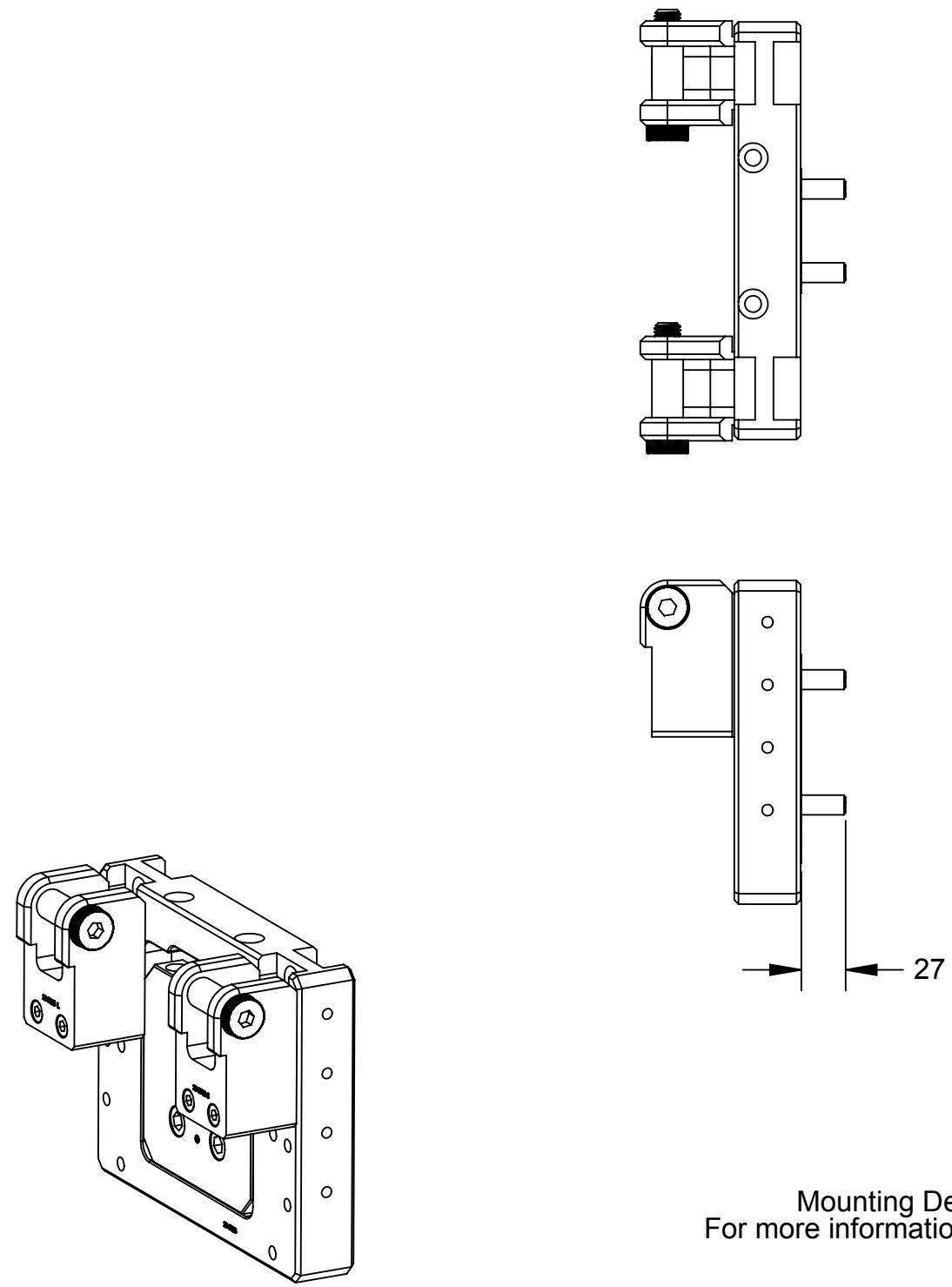

Mounting Details for 9120-TSL-CMH-C500
 For more information see 9230-20-2802 or 9230-20-2805

NOTES: UNLESS OTHERWISE SPECIFIED.

DO NOT SCALE DRAWING. ALL DIMENSIONS ARE IN MILLIMETERS.

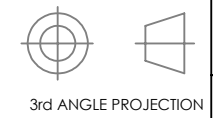

1031 Goodworth Drive, Apex, NC 27539, USA
 Tel: +1.919.772.0115 Email: info@ati-ia.com
 Fax: +1.919.772.8259 www.ati-ia.com
 ISO 9001 Registered Company

PROPERTY OF ATI INDUSTRIAL AUTOMATION, INC. NOT TO BE REPRODUCED IN ANY MANNER EXCEPT ON ORDER OR WITH PRIOR WRITTEN AUTHORIZATION OF ATI.

DRAWN BY: K Potts 6/21/10		TITLE	
CHECKED BY: D Norton 6/21/10		Large Tool Stand Assemblies, Hook-style, QC310	
PROJECT #	100615-1	SHEET	2 OF 3
SCALE	1:4	SIZE	B
DRAWING NUMBER	9230-20-3231	REVISION	04

Rev.	Description	Initiator	Date
-	See Sheet1	-	-

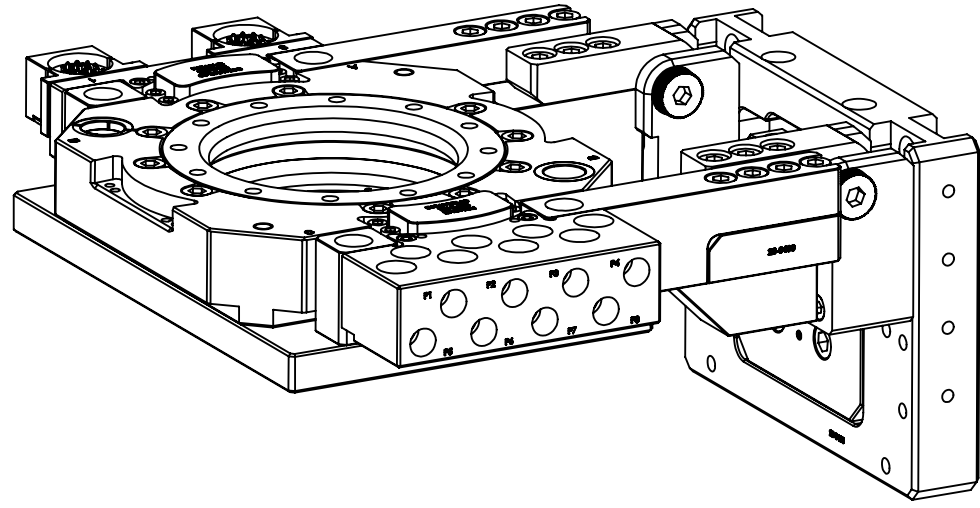
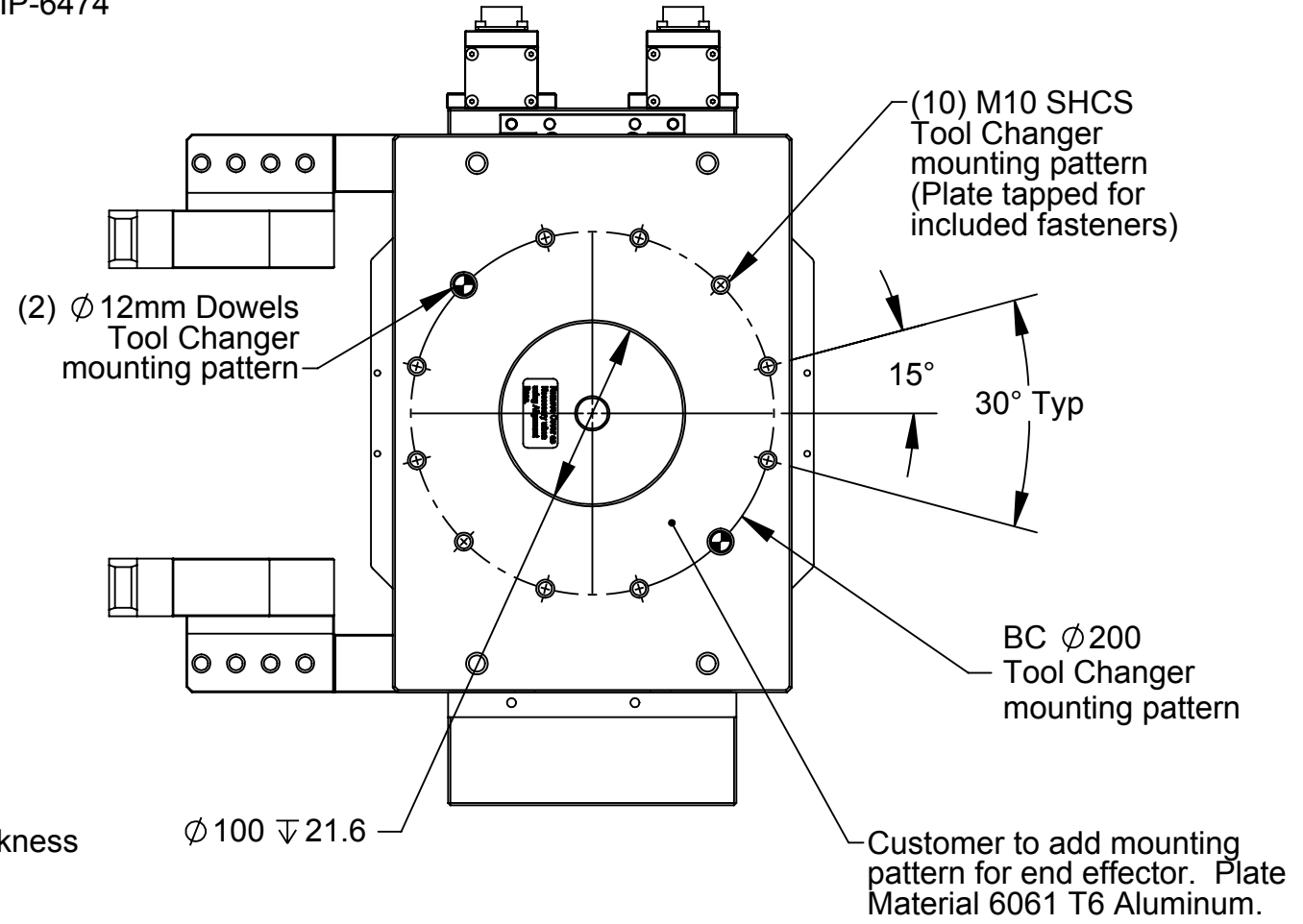
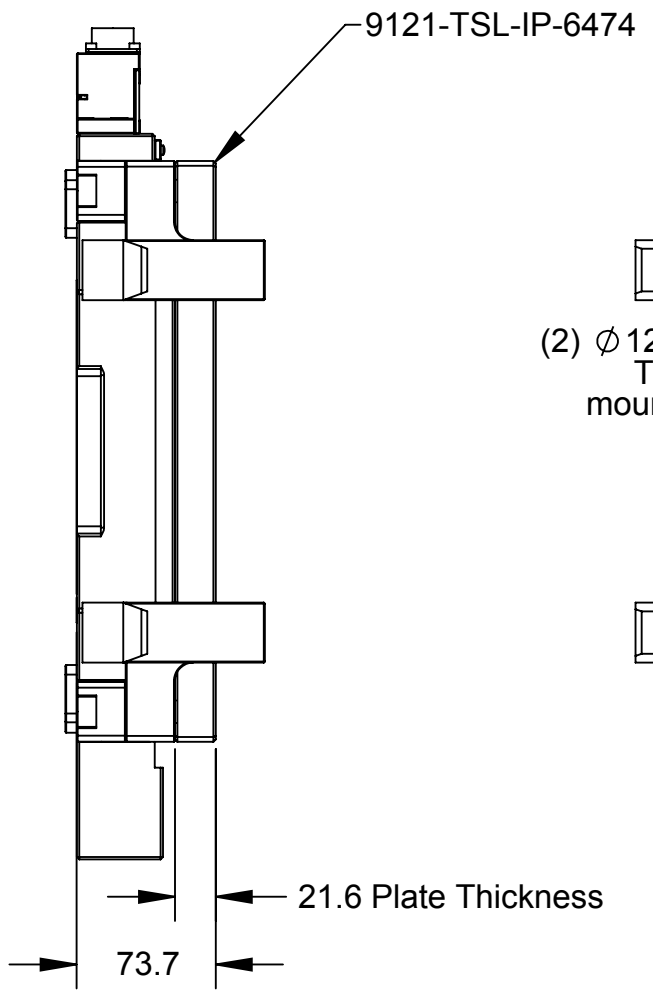
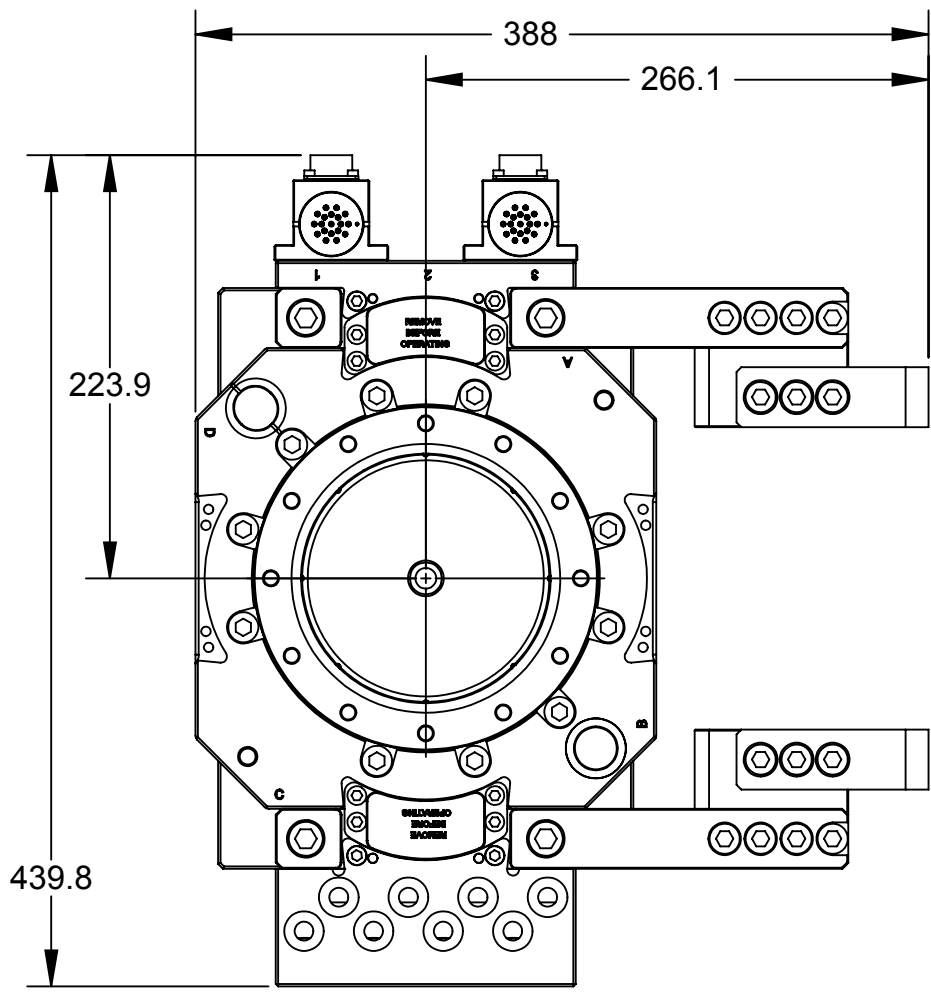

Tool Side Overall Dimensions and Mounting Details for 9121-TSL-IP-6474

NOTES: UNLESS OTHERWISE SPECIFIED.
DO NOT SCALE DRAWING. ALL DIMENSIONS ARE IN MILLIMETERS.

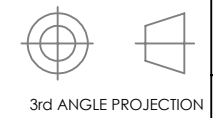

1031 Goodworth Drive, Apex, NC 27539, USA
Tel: +1.919.772.0115 Email: info@ati-ia.com
Fax: +1.919.772.8259 www.ati-ia.com
ISO 9001 Registered Company

PROPERTY OF ATI INDUSTRIAL AUTOMATION, INC. NOT TO BE REPRODUCED IN ANY MANNER EXCEPT ON ORDER OR WITH PRIOR WRITTEN AUTHORIZATION OF ATI.

DRAWN BY: K Potts 6/21/10		TITLE	
CHECKED BY: D Norton 6/21/10		Large Tool Stand Assemblies, Hook-style, QC310	
PROJECT # 100615-1	SHEET 3 OF 3	SCALE 1:4	SIZE B
		DRAWING NUMBER 9230-20-3231	REVISION 04