

Rev.	Description	Initiator	Date
06	Removed Cover from Proposal, Changed Actuator from 35Pulse Motor to PM DC Motor	DAN	9/10/09
07	Added Part Numbers, Prox Sensor on Drive Unit, Removed S26 Module, Showing (2) Tool Presence Sensors	DAN	9/21/09
08	Add Tool Side Mounting Pattern and update Dims.	DSS	1/18/2010
09	Added Sheet 2 with Drive Cylinder Detail	DAN	5/18/10
10	ECO 11431; Drawing Update	ERDO	9/24/2013

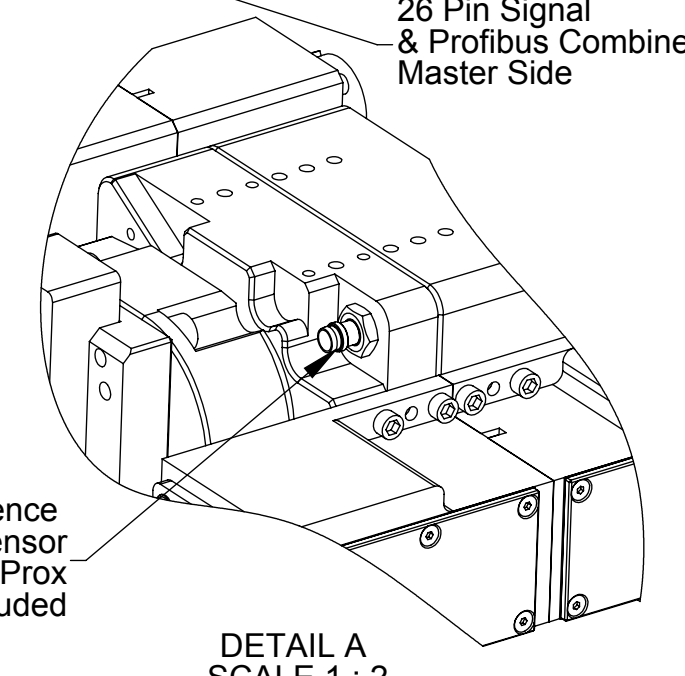

- NOTES:**
- Design is subject to change.
 - Base Utility Coupler features (4) module mounting flats (J16 pattern)
 - Base Master Coupler is compliant to +/-4mm in X-Y-Z directions, 3 degrees angular
 - Base Master Coupler Features a Tool Presence Sensor, 3 Wire PNP Prox.
 - Proposed Drive Unit is a Tolomatic Electric Actuator with the following Specifications:
 - 24VDC Perm Mag Motor with Brake
 - 4 inch total stroke length, 2 inch stroke used

NOTES: UNLESS OTHERWISE SPECIFIED
DO NOT SCALE DRAWING. DRAWN IN SOLIDWORKS.
ALL DIMENSIONS ARE IN MILLIMETERS.

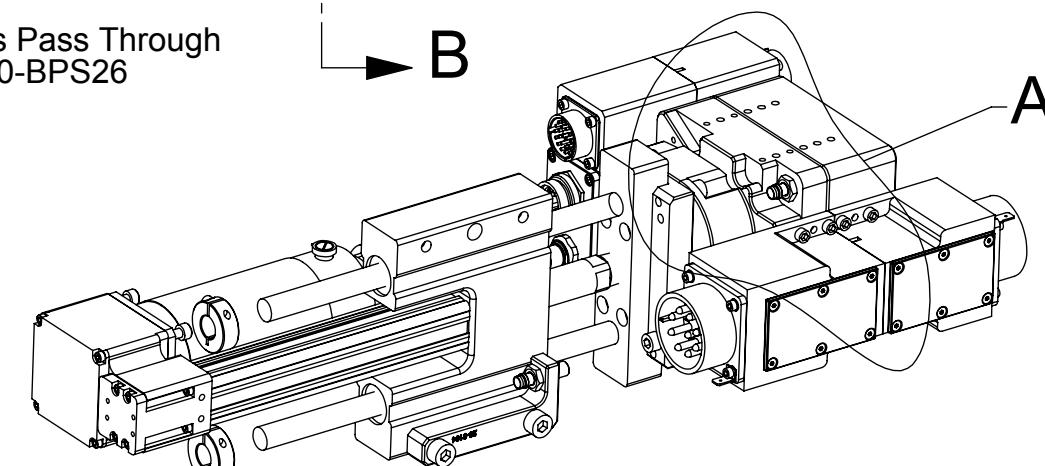
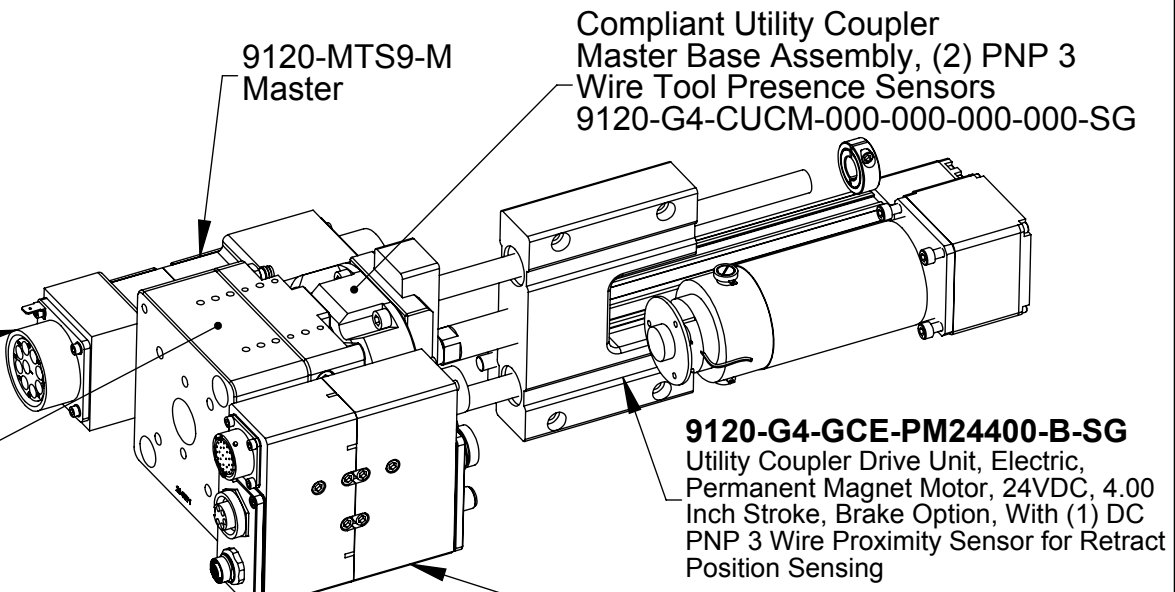
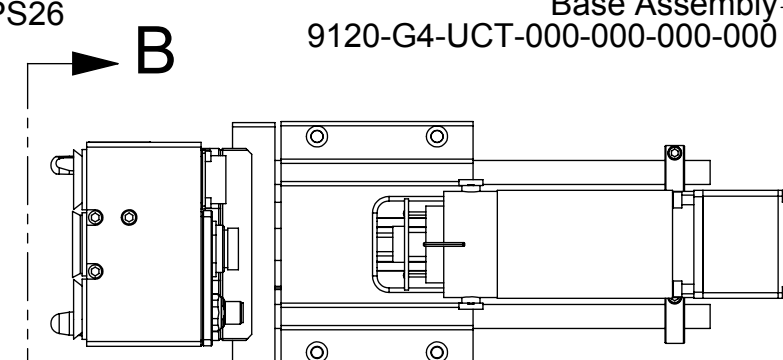
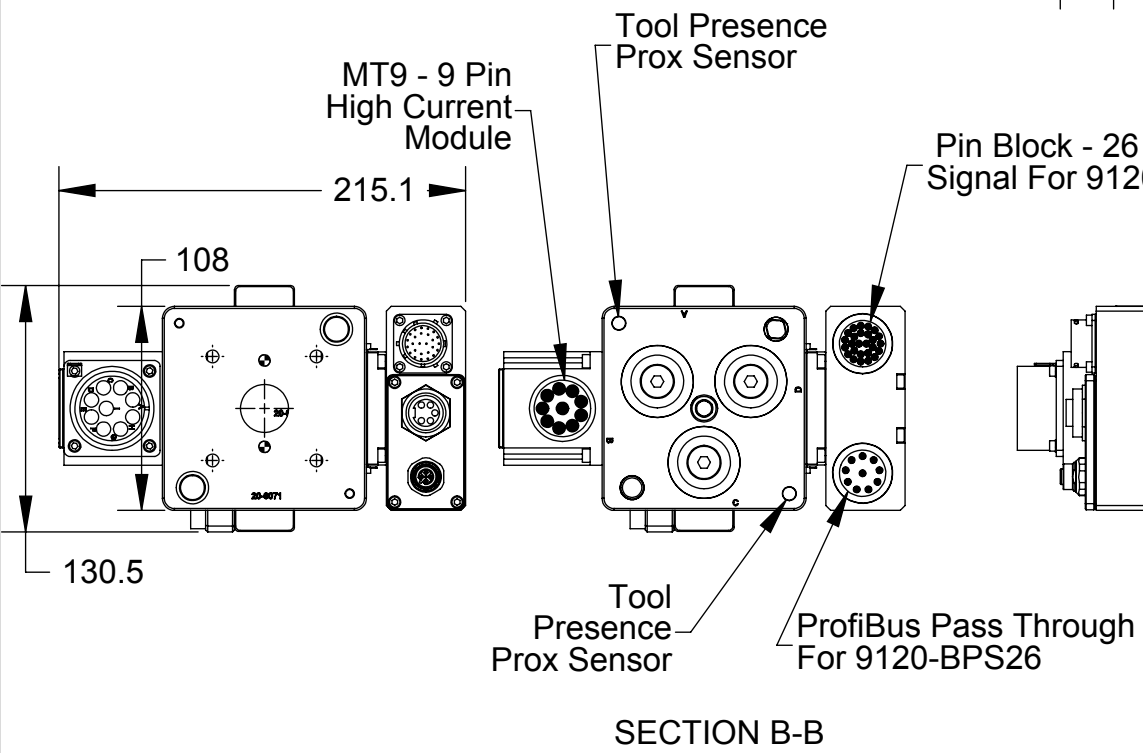
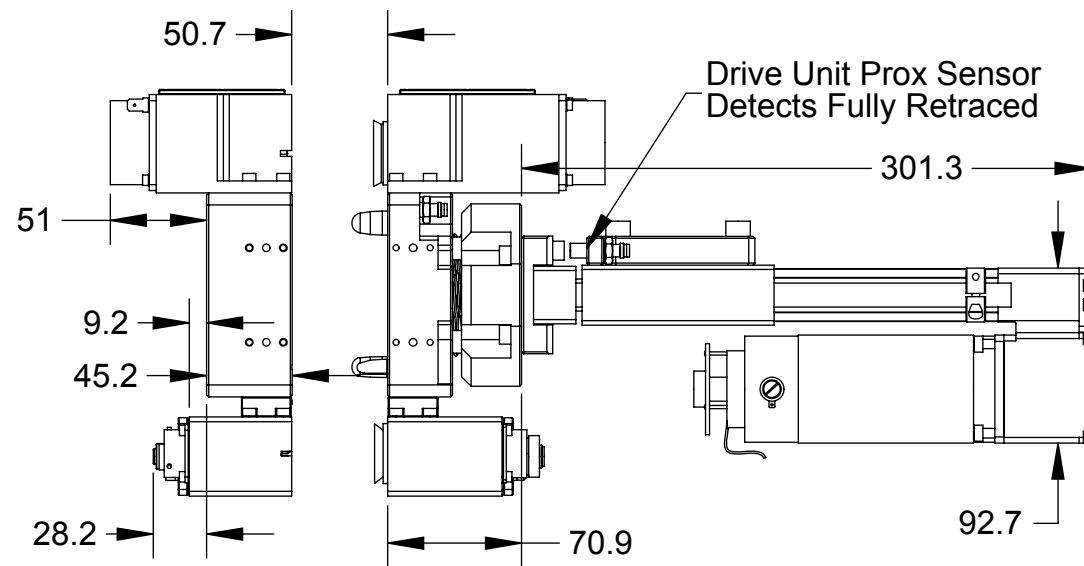
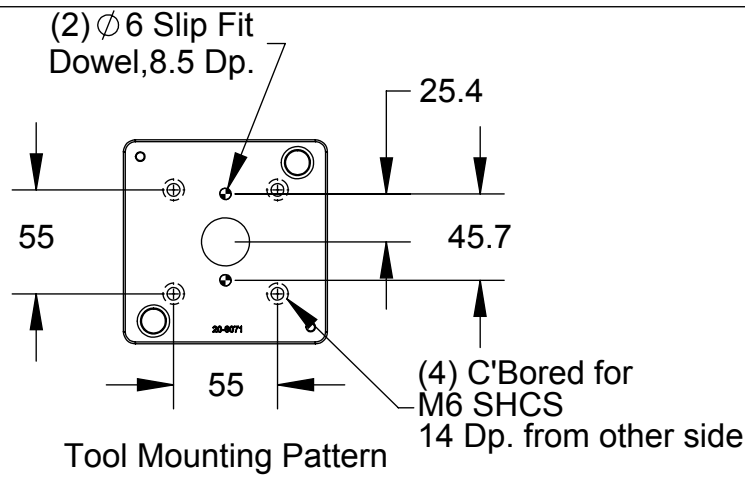

1031 Goodworth Drive, Apex, NC 27539, USA
Tel: +1.919.772.0115 Email: info@ati-ia.com
Fax: +1.919.772.8259 www.ati-ia.com
ISO 9001 Registered Company

PROPERTY OF ATI INDUSTRIAL AUTOMATION, INC. NOT TO BE REPRODUCED IN ANY MANNER EXCEPT ON ORDER OR WITH PRIOR WRITTEN AUTHORIZATION OF ATI.

DRAWN BY: Dan Norton 7/6/09	TITLE Compliant Utility Coupler, MTS9, BPS26, Electric Drive Unit		
CHECKED BY: Kyle Z 5/18/10	SCALE 1:4	SIZE B	REVISION 10
WEIGHT LBS: -----	DRAWING NUMBER 9230-20-2986		DATE
ASSEMBLY REF:	PRODUCT RELEASE # 090701-1		SHEET 1 OF 2

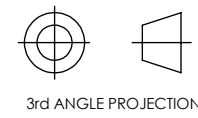

Rev.	Description	Initiator	Date
-	See Sheet1	-	-

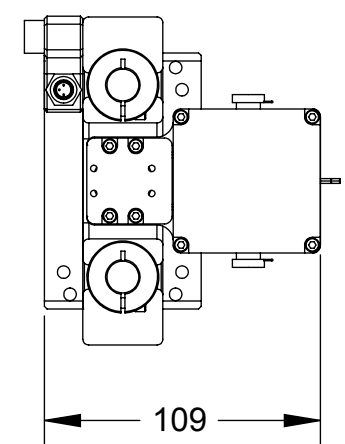
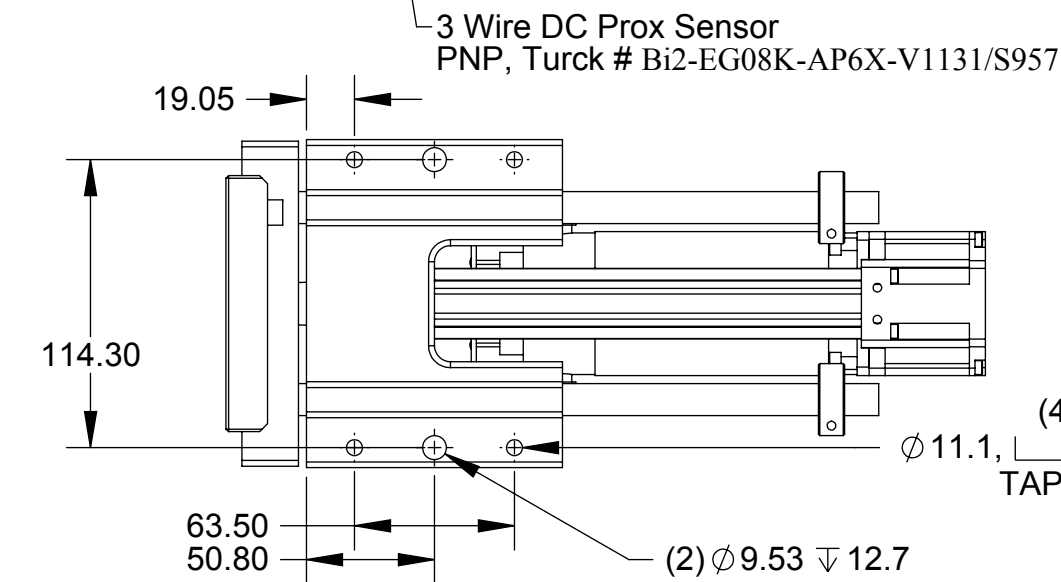
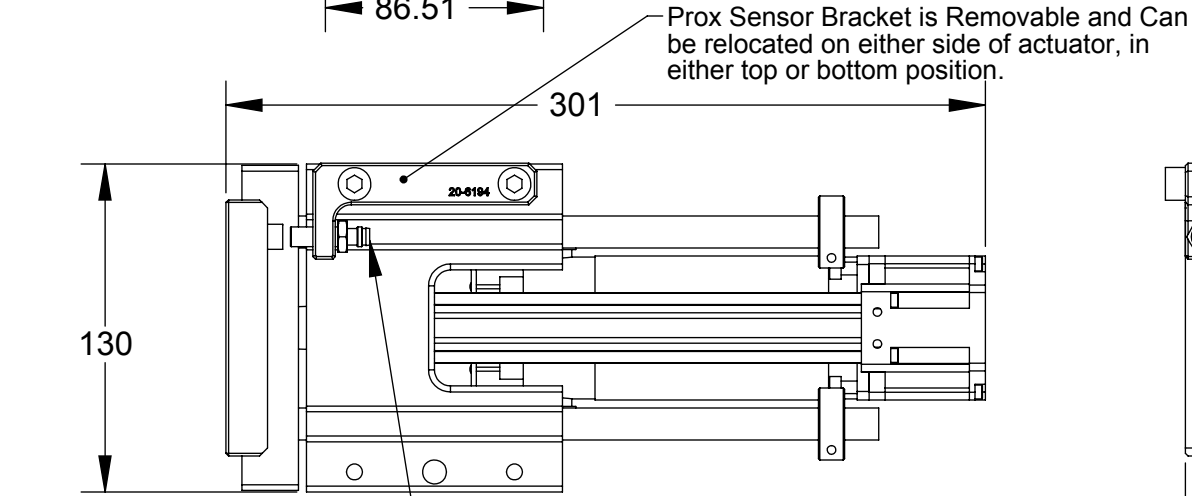
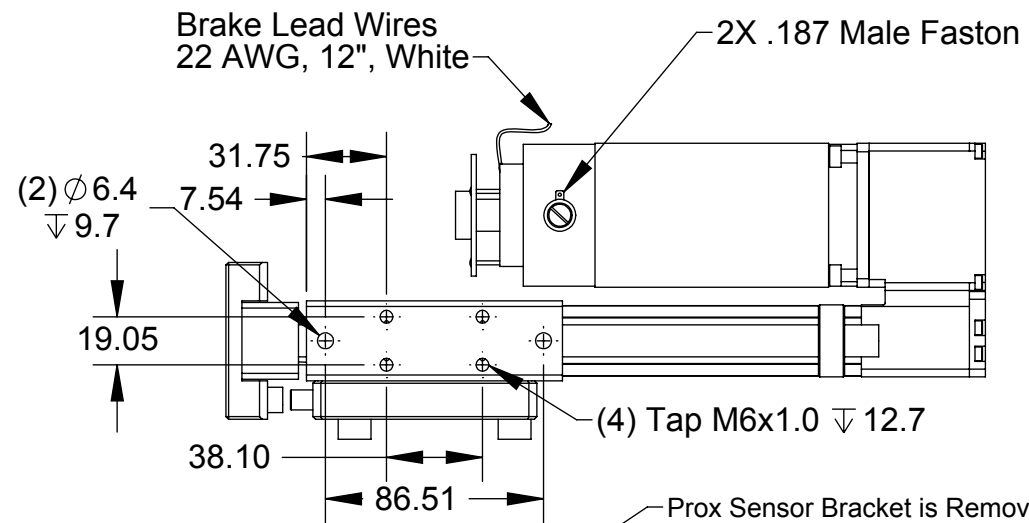

3 Wire DC Prox Sensor
PNP, Turck # Bi2-EG08K-AP6X-V1131/S957

Utility Coupler Tool
Base Assembly
9120-G4-UCT-000-000-000-000

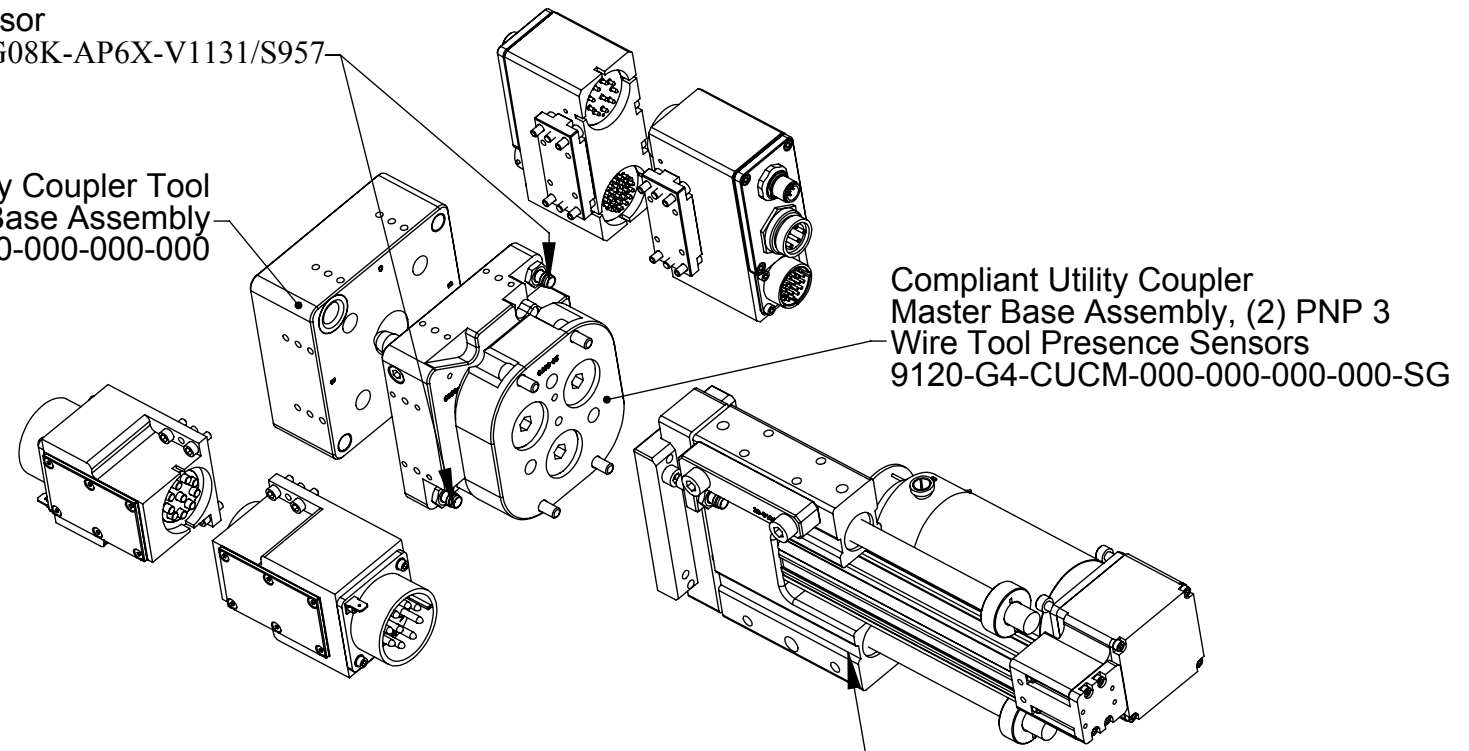

Compliant Utility Coupler
Master Base Assembly, (2) PNP 3
Wire Tool Presence Sensors
9120-G4-CUCM-000-000-000-000-SG

9120-G4-GCE-PM24400-B-SG
Utility Coupler Drive Unit, Electric,
Permanent Magnet Motor, 24VDC, 4.00
Inch Stroke, Brake Option, With (1) DC
PNP 3 Wire Proximity Sensor for Retract
Position Sensing

Exploded View of Utility Coupler
Arrangement

ELECTRIC ACTUATOR DETAILS 9120-G4-GCE-PM24400-B-SG

Motor Characteristics		
Rated Voltage DC	24	Volts
Rated Current	6.1	Amps
Rated Power Out	145	Watts
No Load Current	.86	Amps
Rated Torque	40	oz-in
Brake Data		
Torque	3	lb-in
Rated Voltage DC	24	Volts
Rated Current	.19	Amps

NOTES: UNLESS OTHERWISE SPECIFIED
DO NOT SCALE DRAWING. DRAWN IN SOLIDWORKS.
ALL DIMENSIONS ARE IN MILLIMETERS.



1031 Goodworth Drive, Apex, NC 27539, USA
Tel: +1.919.772.0115 Email: info@ati-ia.com
Fax: +1.919.772.8259 www.ati-ia.com
ISO 9001 Registered Company

PROPERTY OF ATI INDUSTRIAL AUTOMATION, INC. NOT TO BE REPRODUCED IN ANY MANNER
EXCEPT ON ORDER OR WITH PRIOR WRITTEN AUTHORIZATION OF ATI.

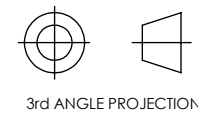

DRAWN BY: Dan Norton 7/6/09	TITLE Compliant Utility Coupler, MTS9, BPS26, Electric Drive Unit		
CHECKED BY: Kyle Z 5/18/10	SCALE 1:3	SIZE B	REVISION 10
WEIGHT LBS: -----	DRAWING NUMBER 9230-20-2986		DATE
ASSEMBLY REF:	PRODUCT RELEASE # 090701-1		SHEET 2 OF 2