

Rev.	Description	Initiator	Date
04	Updated drawing title.	PS	4/20/2005

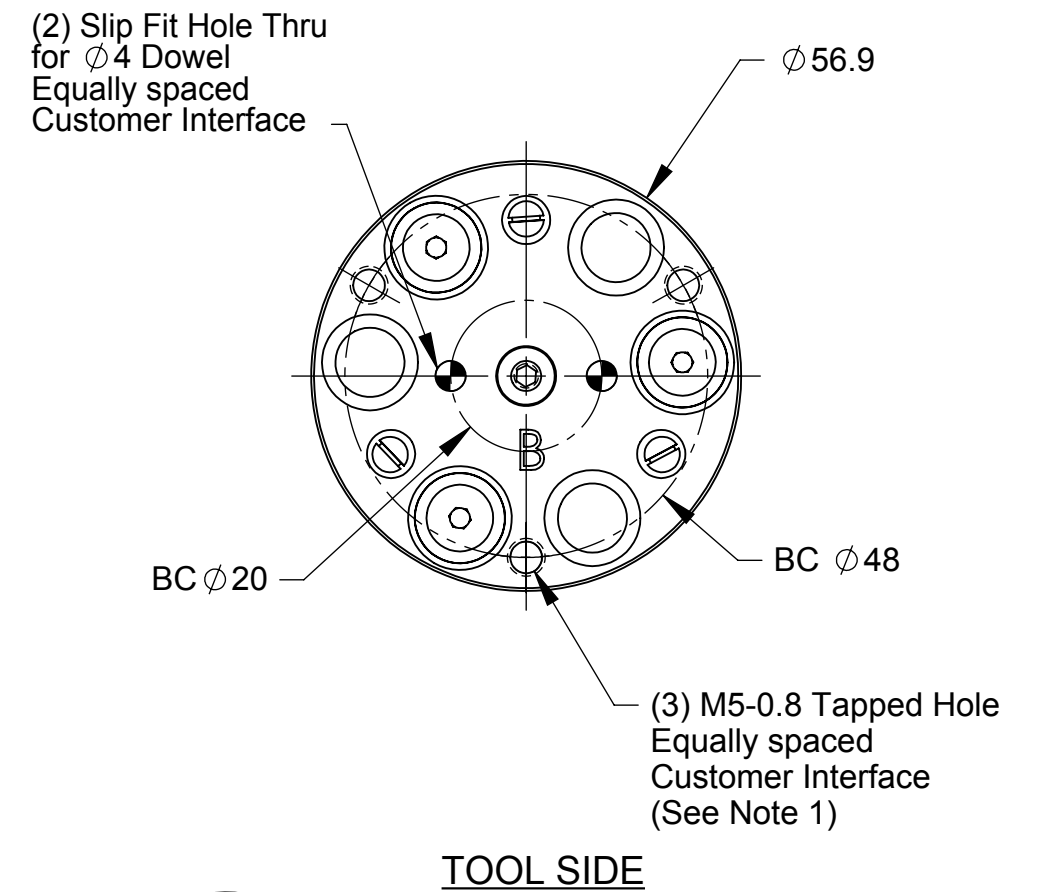

- Notes:
1. Also option of using M4 SHCS thru the M5 tapped hole for mounting.
 2. Lock-up optional.

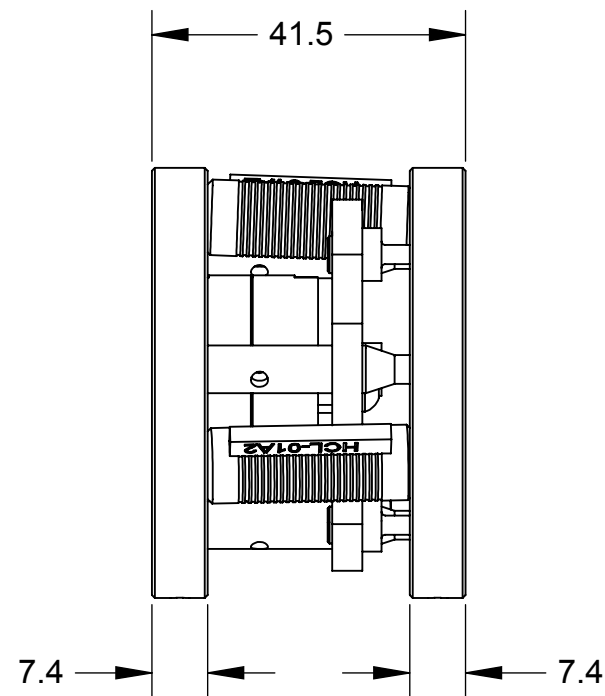
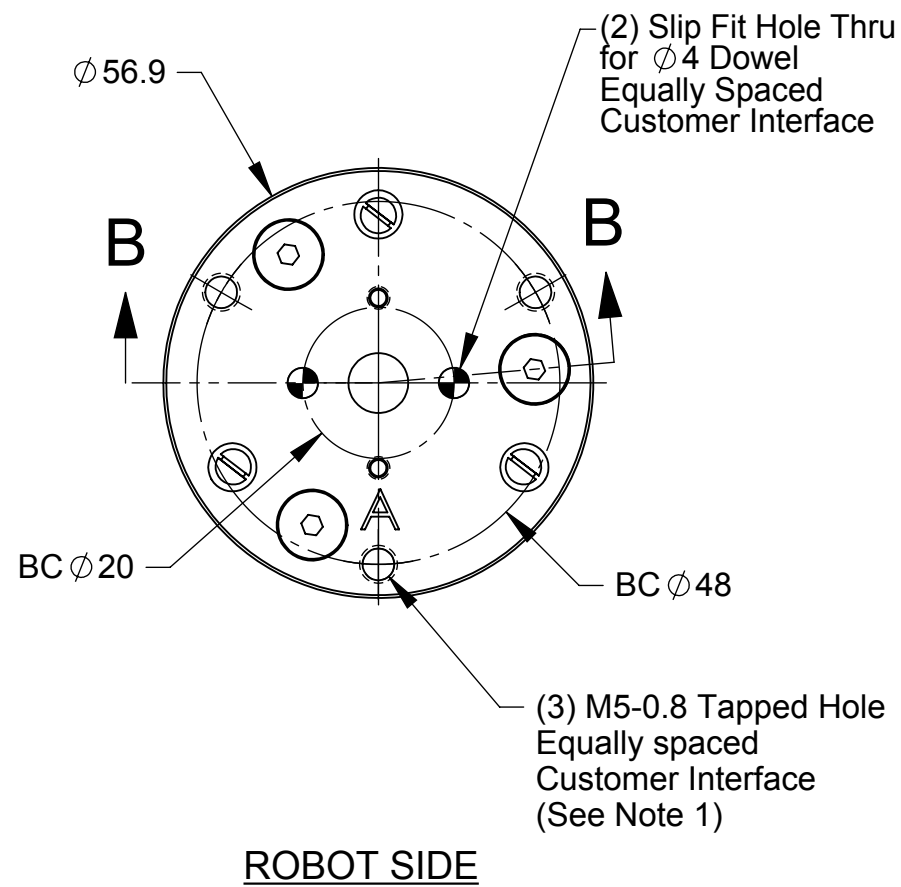
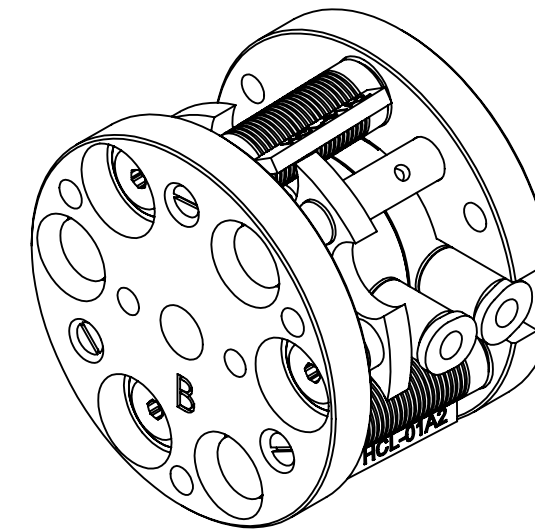
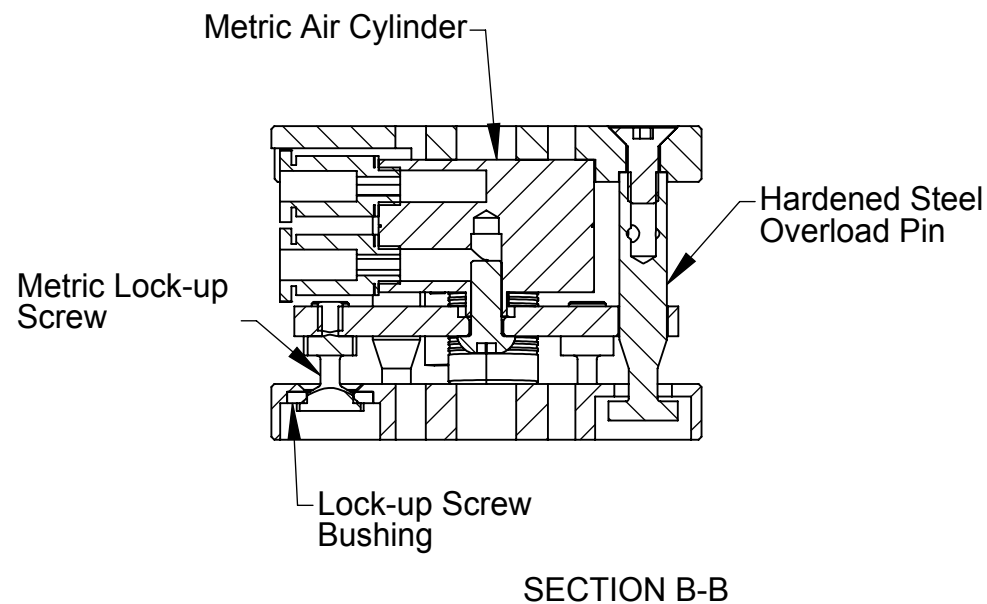

Part Number:
9116-001-A-L

NOTES: UNLESS OTHERWISE SPECIFIED
 DO NOT SCALE DRAWING. DRAWN IN SOLIDWORKS.
 ALL DIMENSIONS ARE IN MILLIMETERS.



1031 Goodworth Drive, Apex, NC 27539, USA
 Tel: +1.919.772.0115 Email: info@ati-ia.com
 Fax: +1.919.772.8259 www.ati-ia.com
 ISO 9001 Registered Company

DRAWN BY: J.Snape, 9/6/04		TITLE	
CHECKED BY: P.Sparrow, 9/10/04		Compensator 9116 Series 000 w/ Lock-up	
WEIGHT LBS: 0.4	SCALE 1:1	SIZE B	DRAWING NUMBER 9230-15-1026-04
ASSEMBLY REF:	PRODUCT RELEASE # 040123-1 DATE:		SHEET 1 OF 1

