

Rev.	Description	Initiator	Date
02	Eco 13245; Release	LJH	4/2/2015
03	ECO 15250; Corrected explode lines and updated Note to standard	SZJ	3/7/2017

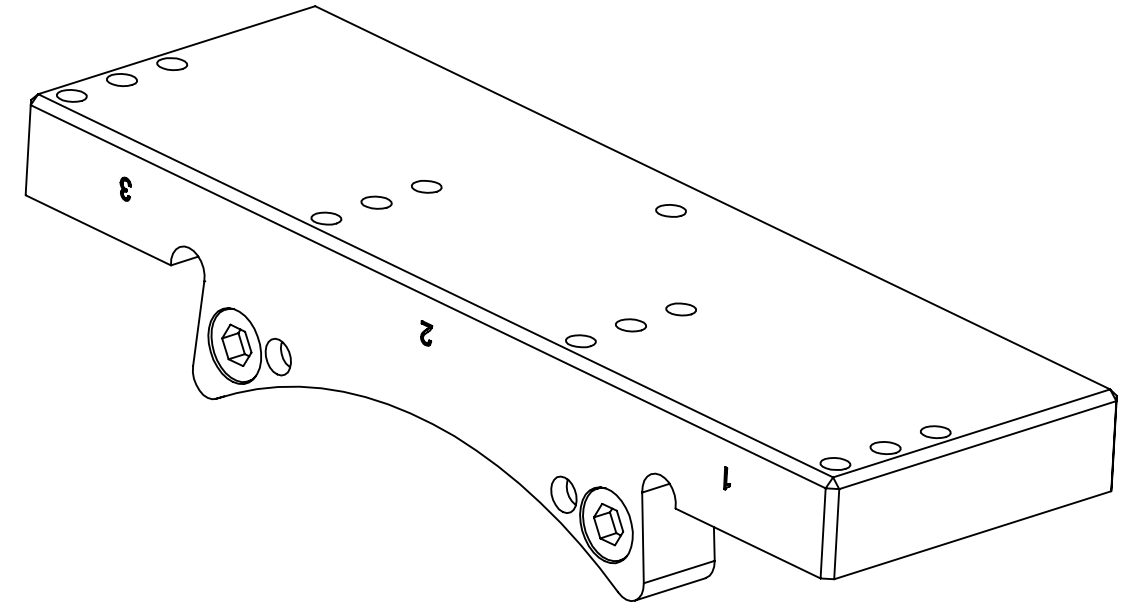
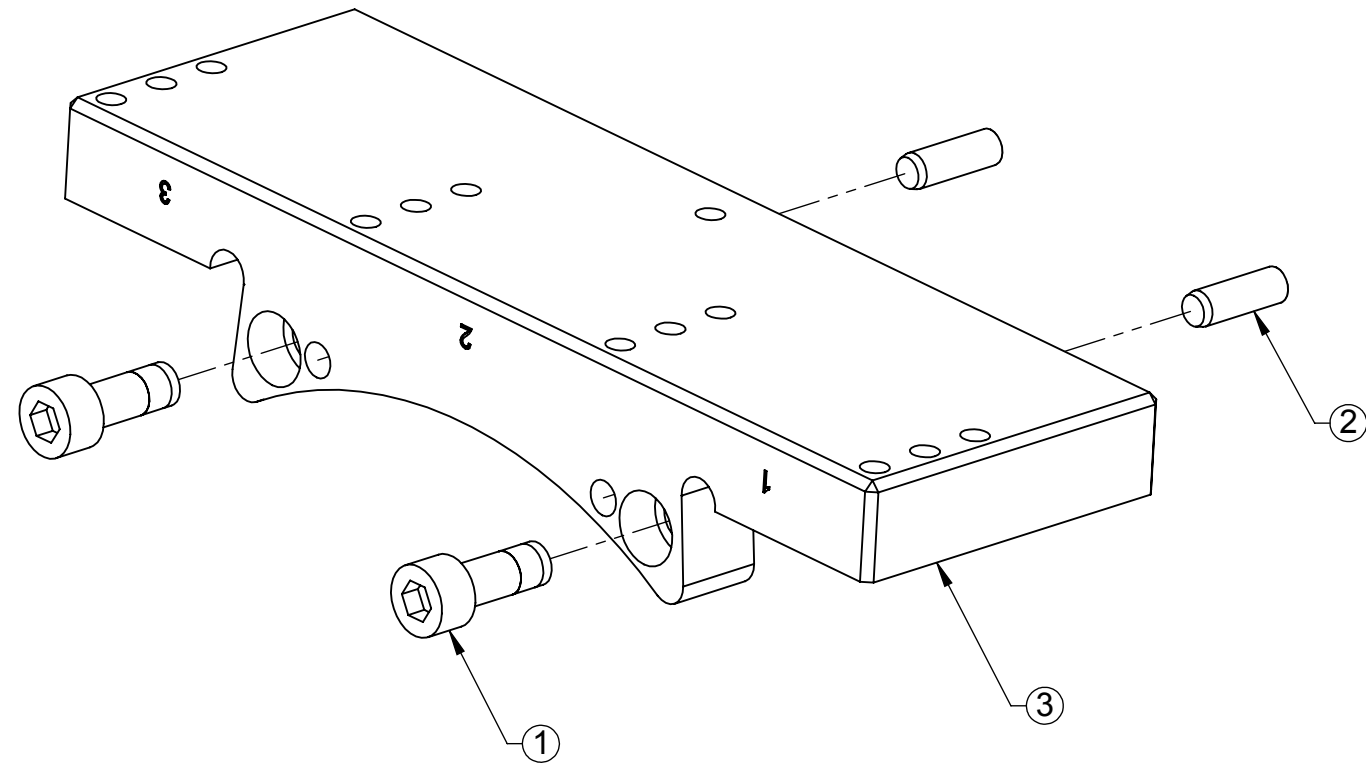

ITEM NO.	QTY.	PART NUMBER	DESCRIPTION
1	2	3500-1066016-15A	M6-1 x 16mm SHCS, Blue, Pre-Applied
2	2	3540-0105016-11	5mm x 16mm Dowel Alloy Steel
3	1	3700-20-9288	Master Adapter Plate Common Ledge Mtg to J16 w/ Added M4 Tapped Hole

NOTES: UNLESS OTHERWISE SPECIFIED.

DO NOT SCALE DRAWING. ALL DIMENSIONS ARE IN INCHES.



3rd ANGLE PROJECTION



1031 Goodworth Drive, Apex, NC 27539, USA
 Tel: +1.919.772.0115 Email: info@ati-ia.com
 Fax: +1.919.772.8259 www.ati-ia.com
 ISO 9001 Registered Company

PROPERTY OF ATI INDUSTRIAL AUTOMATION, INC. NOT TO BE REPRODUCED IN ANY MANNER EXCEPT ON ORDER OR WITH PRIOR WRITTEN AUTHORIZATION OF ATI.

Notes:

1. Bag loose items.

DRAWN BY: P. Luczka 4/2/15		TITLE	
CHECKED BY: W. Berrocal 4/2/15		JJ2 Master Adapter Assembly w/ Added M4 Tapped Hole	
PROJECT #	SHEET 1 OF 1	SCALE	SIZE
		1:1	B
		DRAWING NUMBER	REVISION
		9121-JJ2Z1-M	03