

Rev.	Description	Initiator	Date
01	Initial Release	PDL	11/28/2011
02	Eco 11944; Dissolved subassembly 9005-20-1485 in favor of the discrete parts listed in drawing BOM. Removed cleat 9005-20-1199.	LJH	4/29/2014
03	ECO 20044; Moved (7) dowel pins to lower ledge. Updated title block	DS	7/9/2021

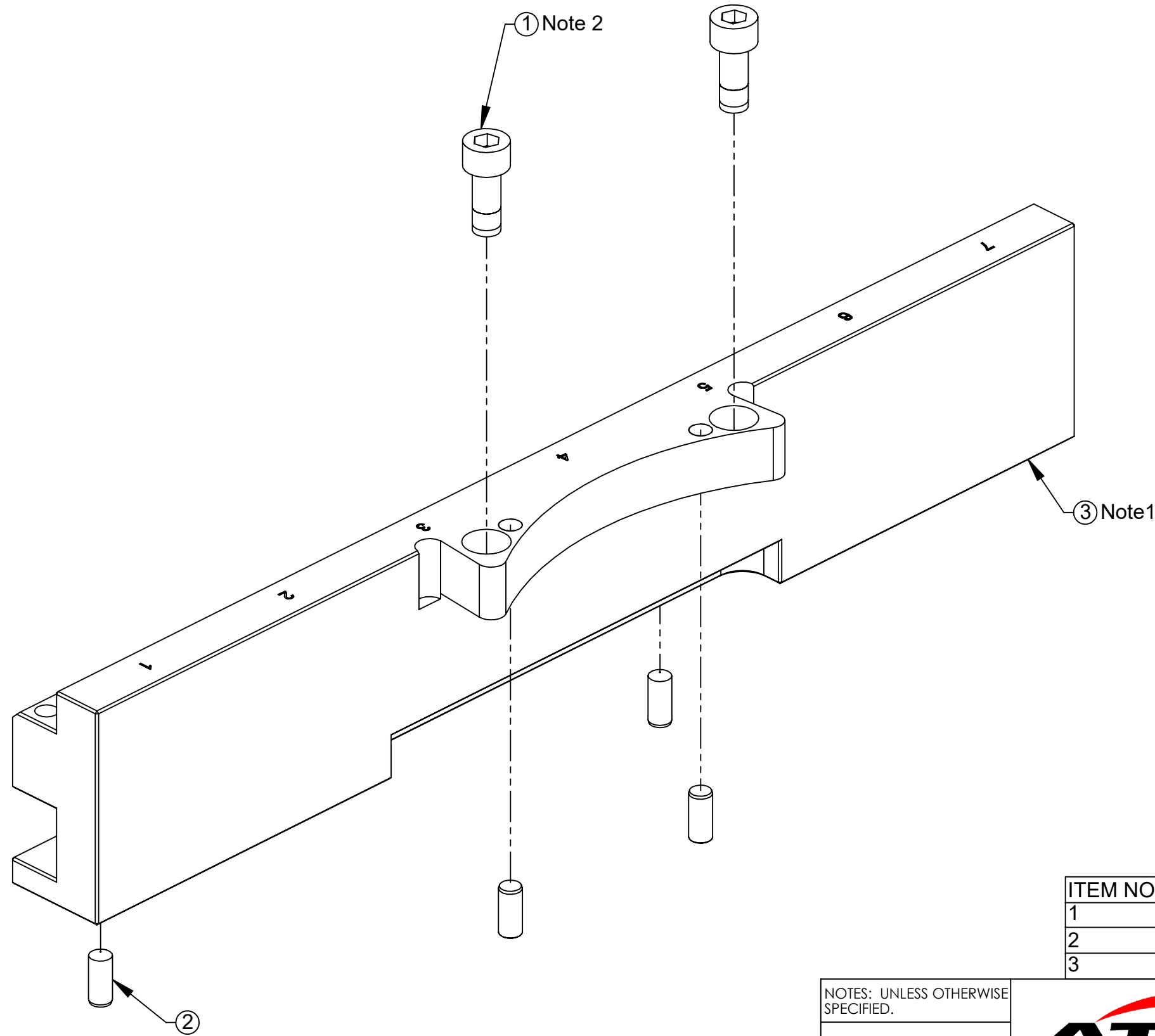

Notes:

1. Install 7 dowel pins flush (+/- 0.010) with surface.
2. If mounting to QC, refer to work instructions, otherwise bag dry loose fasteners.

ITEM NO.	QTY.	PART NUMBER	DESCRIPTION
1	2	3500-1066016-15A	M6-1 x 16mm SHCS, Blue, Pre-Applied
2	9	3540-0105012-11	DOWEL PIN, M5 X 12
3	1	3700-20-5681	EN2 Mounting Rail, 7-Position, Tool

NOTES: UNLESS OTHERWISE SPECIFIED.

DO NOT SCALE DRAWING. ALL DIMENSIONS ARE IN INCHES.



3rd ANGLE PROJECTION



1031 Goodworth Drive, Apex, NC 27539, USA
 Tel: +1.919.772.0115 www.ati-ia.com
 Fax: +1.919.772.8259 ISO 9001 Registered Company

PROPERTY OF ATI INDUSTRIAL AUTOMATION, INC. NOT TO BE REPRODUCED IN ANY MANNER EXCEPT ON ORDER OR WITH PRIOR WRITTEN AUTHORIZATION OF ATI.

DRAWN BY: P.Luczka, 11/17/11		TITLE	
CHECKED BY: W.Berrocal, 11/28/11		Rail Style, Tool Ledge Mount Adapter, 7-Positions	
PROJECT #	--	SCALE	1:1
SHEET	1 OF 1	SIZE	B
		DRAWING NUMBER	9121-JJ16-T
		REVISION	03