

Rev.	Description	Initiator	Date
01	Initial Release	PDL	11/28/2011
02	Eco 11025; Flatten Bill of material (eliminate sub-assembly in favor of piece parts.) Add notes. Eco 11961; Removed tooling info from NOTE 1. Deleted Notes 3, 4, & 5. Removed (2) leaders for balloon 2. Added balloon 2. Added Note 1 callout. Removed Cleat 9005-20-1198 and associated dowels 3540-0405012-11.	LJH	5/17/2013
03		DS	4/28/2014

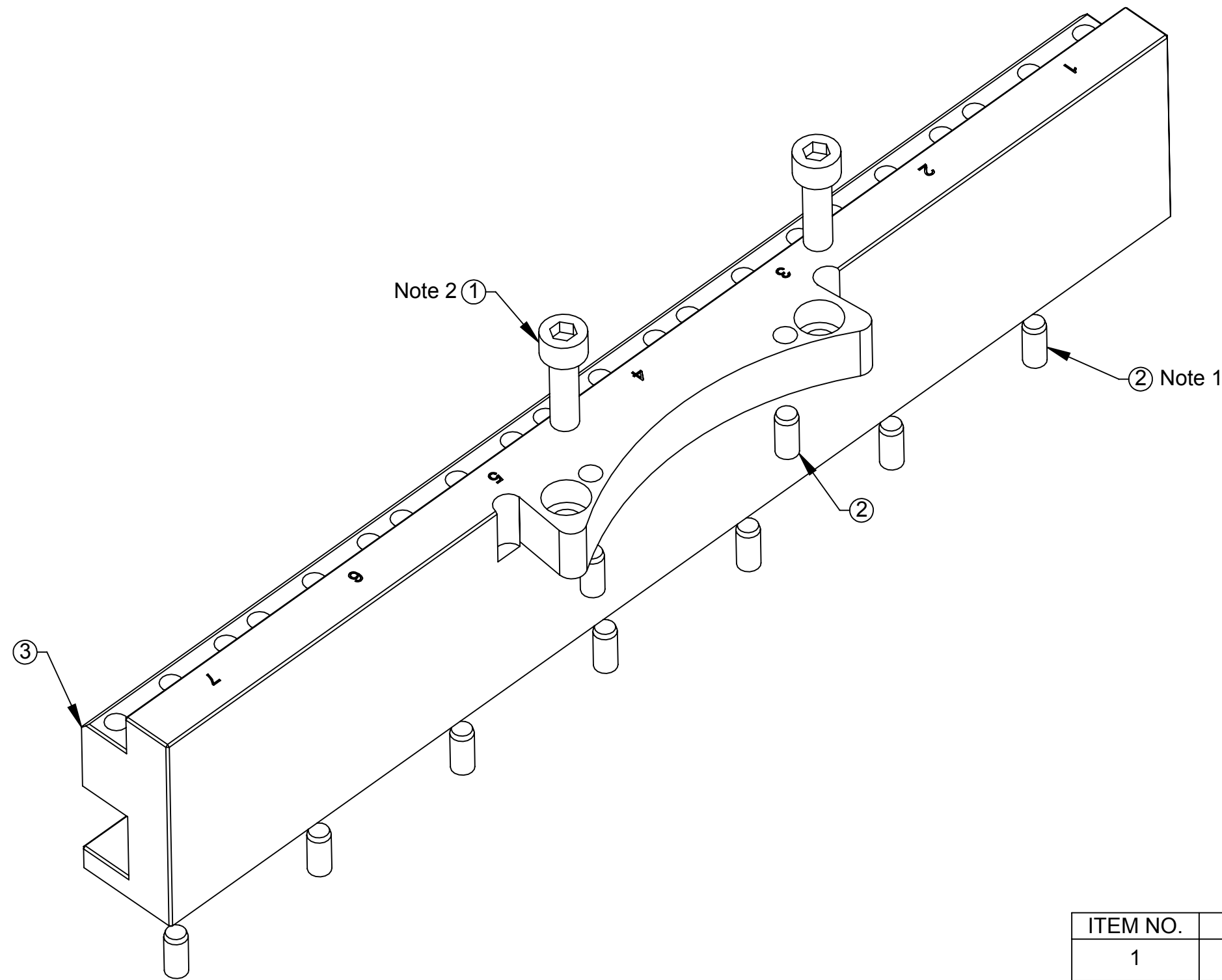

NOTES:  
 1) Install 7 dowel pins flush (+/- 0.010" ) with surface.  
 2) If mounting to QC, refer to work instruction, otherwise bag dry loose fasteners.

ITEM NO.	QTY.	PART NUMBER	DESCRIPTION
1	2	3500-1066020-15A	M6 x 20mm SHCS Blue Dyed Magni ND Microspheres
2	9	3540-0105012-11	5mm x 12mm Dowel Alloy Steel
3	1	3700-20-5680	EN2 Mounting Rail, 7-Position, Master

NOTES: UNLESS OTHERWISE SPECIFIED.  
 DO NOT SCALE DRAWING. ALL DIMENSIONS ARE IN INCHES.



1031 Goodworth Drive, Apex, NC 27539, USA  
 Tel: +1.919.772.0115 Email: info@ati-ia.com  
 Fax: +1.919.772.8259 www.ati-ia.com  
 ISO 9001 Registered Company

PROPERTY OF ATI INDUSTRIAL AUTOMATION, INC. NOT TO BE REPRODUCED IN ANY MANNER EXCEPT ON ORDER OR WITH PRIOR WRITTEN AUTHORIZATION OF ATI.

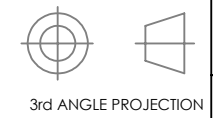

DRAWN BY: P.Luczka, 11/17/11		TITLE	
CHECKED BY: W.Berrocal, 11/28/11		Rail Style, Master Ledge Mount Adapter, 7-Positions, 1.625" Spacing	
PROJECT # -	SHEET 1 OF 1	SCALE	REVISION
		1:5	03
		SIZE	DRAWING NUMBER
		B	9121-JJ16-M