

PROPERTY OF ATI INDUSTRIAL AUTOMATION, INC.
 NOT TO BE REPRODUCED IN ANY MANNER EXCEPT ON
 ORDER OR WITH PRIOR WRITTEN AUTHORIZATION OF ATI.

Rev.	Description	Initiator	Date
01	Initial Drawing	DAN	2/28/07

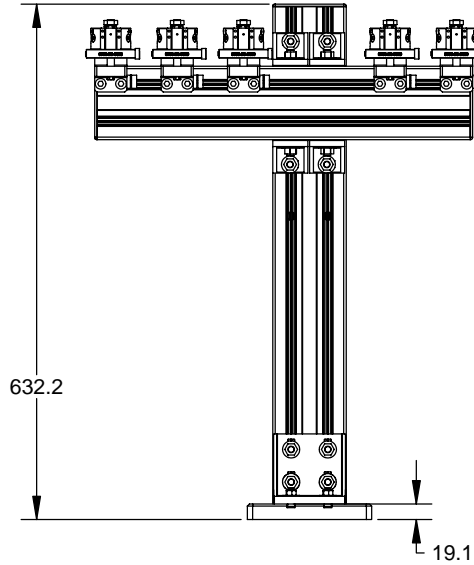
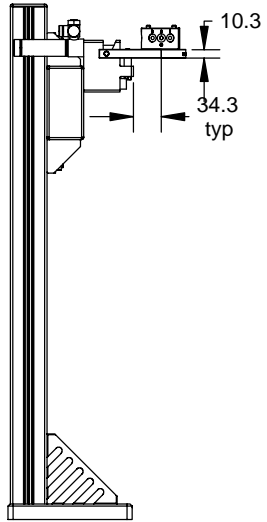
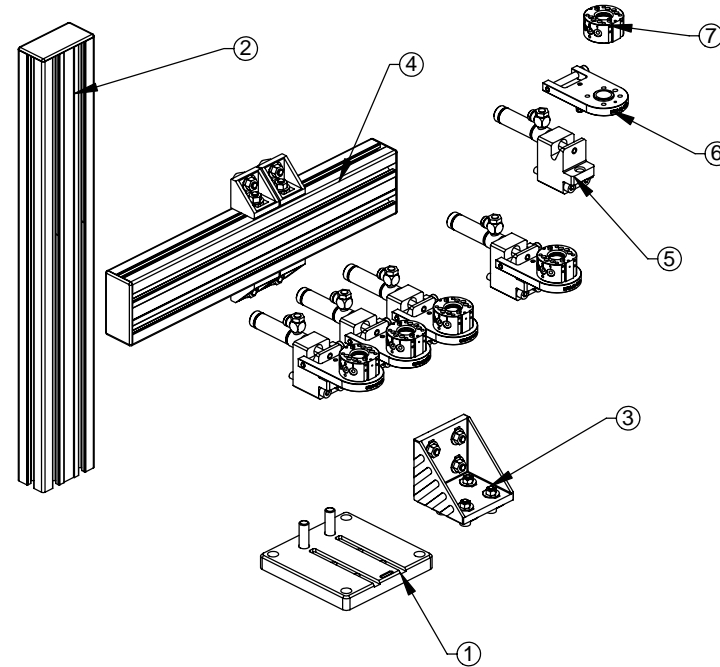
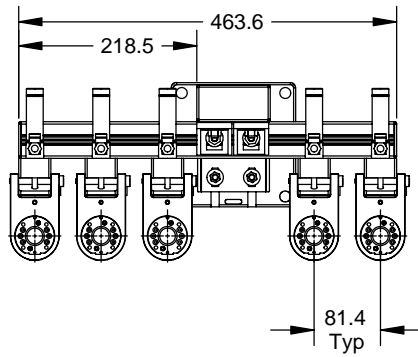

ITEM NO.	QTY.	PART NUMBER	DESCRIPTION
1	1	9120-TSS-3311	Small Tool Stand Base
2	1	9120-TSS-1020	Tool Stand Rail Assembly 610mm Long
3	1	9120-TSS-1030	Tool Stand Gusset Assembly
4	1	9120-TSM-HM-3323	TSM Horizontal Module, 18"
5	5	9120-TSS-5028	TSS Mounting Block with Lock Cylinder
6	5	9120-TSS-5029	TSS Tool Interface Blank For QC 5,10,11
7	5	9120-005T-000-000	

NOTES: UNLESS OTHERWISE SPECIFIED
 DO NOT SCALE DRAWING. DRAWN IN SOLIDWORKS.
 ALL DIMENSIONS ARE IN MILLIMETERS.



1031 Goodworth Drive, Apex, NC 27539, USA
 Tel: +1.919.772.0115 Email: info@ati-ia.com
 Fax: +1.919.772.8259 www.ati-ia.com
 ISO 9001 Registered Company

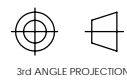

DRAWN BY: Dan Norton 2/28/07	TITLE: Locking TSS for QC-5, TSS Post, 5 Tools		
CHECKED BY:	SCALE: 1:6	SIZE: B	DRAWING NUMBER: 9230-20-2562-01
WEIGHT LBS:	PRODUCT RELEASE # 061011-2 DATE: SHEET 1 OF 1		
ASSEMBLY REF:			