

PROPERTY OF ATI INDUSTRIAL AUTOMATION, INC.
 NOT TO BE REPRODUCED IN ANY MANNER EXCEPT ON
 ORDER OR WITH PRIOR WRITTEN AUTHORIZATION OF ATI.

REVISION	DESCRIPTION	INITIATOR	DATE
01	Initial Drawing	DAN	6/10/04

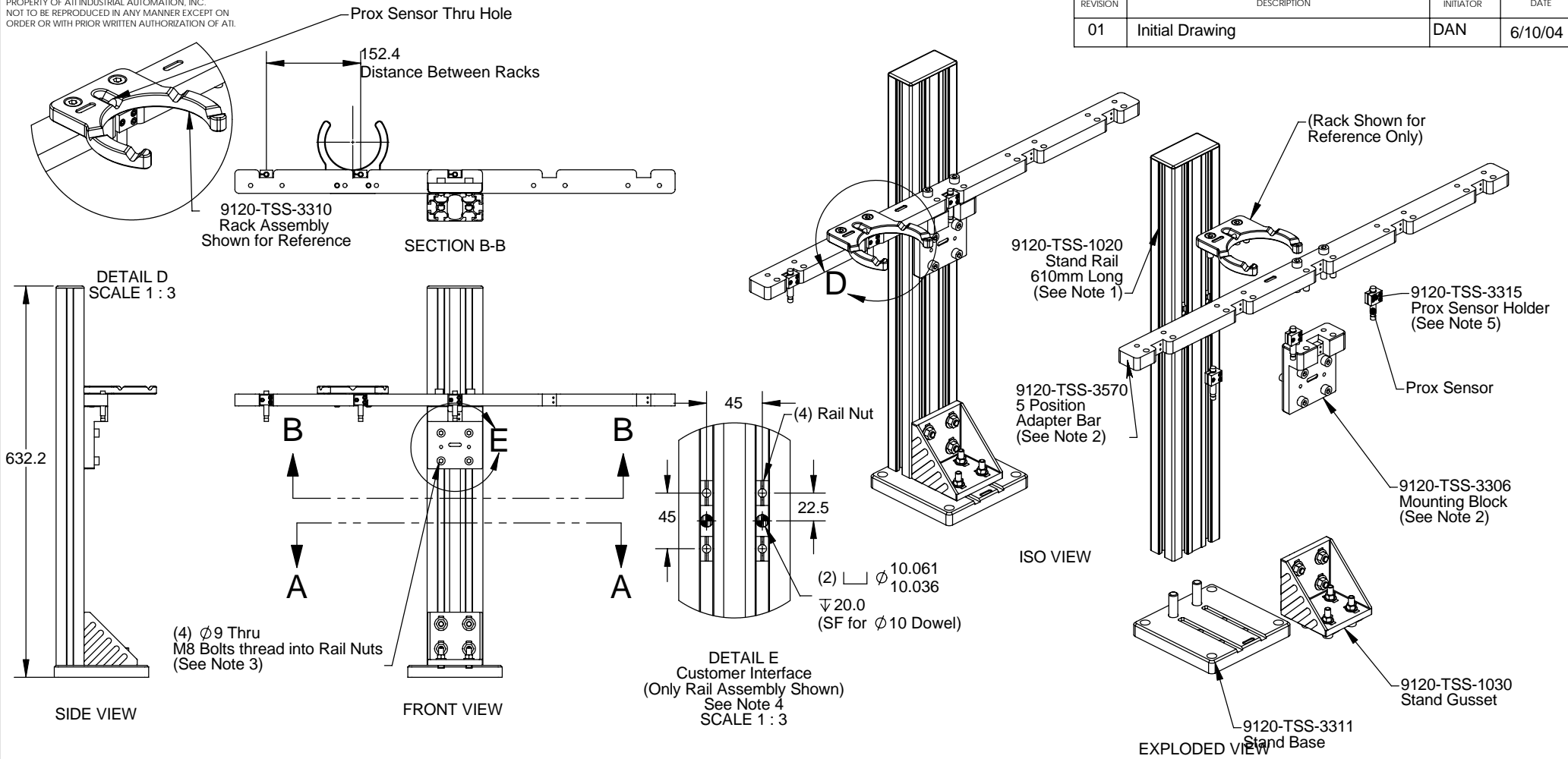

- NOTES:
- Customer can specify other rail lengths
 - Mounting Block and 5 Position Bar are compatible with any TSS Rack
 - Use Loctite Threadlocker 242 on all fasteners. Tighten to 221 in-lbs.
 - Customer to machine dowel holes into rail once desired height is set.
 - Sensor Holder is compatible with any barrel-type $\varnothing 8\text{mm}$ Sensor.

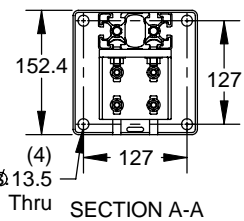

NOTES: UNLESS OTHERWISE SPECIFIED

DO NOT SCALE DRAWING. DRAWN IN SOLIDWORKS. ALL DIMENSIONS ARE IN MILLIMETERS.

3rd ANGLE PROJECTION



1031 Goodworth Drive, Apex, NC 27502, USA
 Tel: +1.919.772.0115 Email: info@ati-ia.com
 Fax: +1.919.772.8259 www.ati-ia.com
 ISO 9001 Registered Company

DRAWN BY: Dan Norton, 2/3/03		TITLE: Tool Stand Common Parts for QC-5 thru 21	
CHECKED BY:		SCALE: 1:6	SIZE: B
WEIGHT LBS:		DRAWING NUMBER: 9230-20-1914-01	
ASSEMBLY REF:		PRODUCT RELEASE # 010730-3 DATE: SHEET 1 OF 1	