

Rev.	Description	Initiator	Date
01	Initial Issue	JEW	2/13/2007

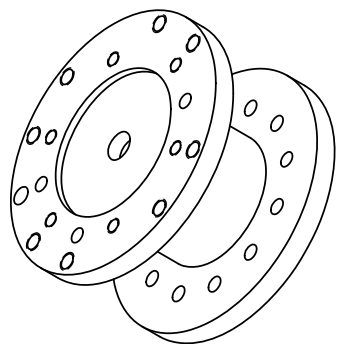

- Notes:**
- Part # 9121-210-A-4953 shown without optional boss. Additional configurations including a boss plate on the master side are available.
  - Welded by certified welder and magna flux inspected.

NOTES: UNLESS OTHERWISE SPECIFIED  
 DO NOT SCALE DRAWING. DRAWN IN SOLIDWORKS.  
 ALL DIMENSIONS ARE IN MILLIMETERS.

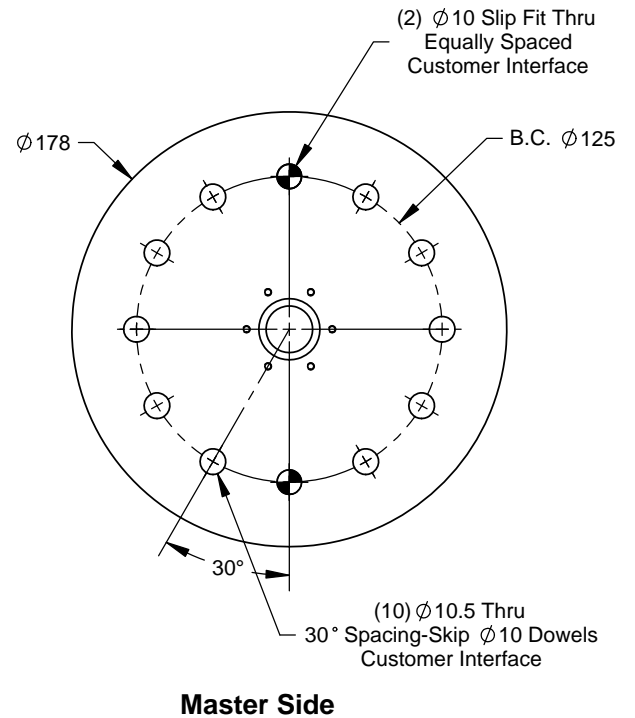
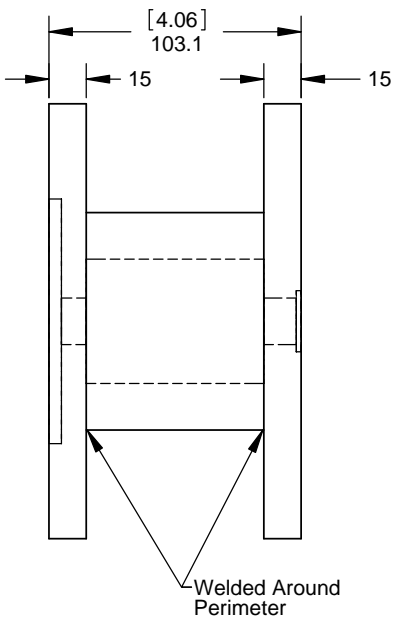
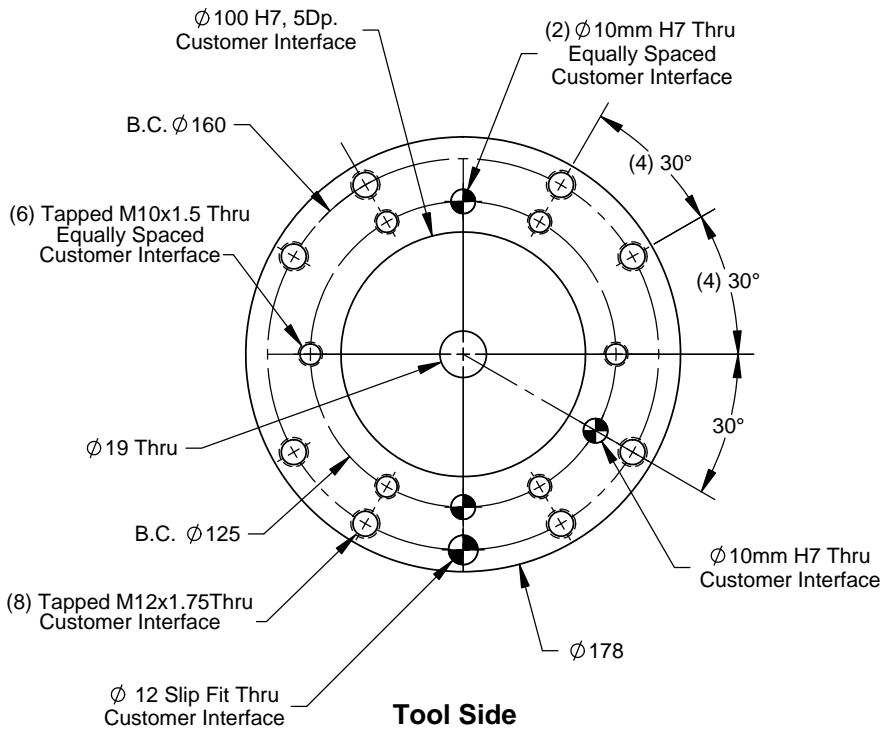
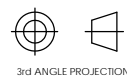

3rd ANGLE PROJECTION



1031 Goodworth Drive, Apex, NC 27539, USA  
 Tel: +1.919.772.0115 Email: info@ati-ia.com  
 Fax: +1.919.772.8259 www.ati-ia.com  
 ISO 9001 Registered Company

DRAWN BY: J. Williams 2/13/07	TITLE: QC-210 Spacer Plate		
CHECKED BY: R. Heavner 2/20/07	SCALE: 1:2	SIZE: B	DRAWING NUMBER: 9230-20-2538-01
WEIGHT LBS: 17.009	PRODUCT RELEASE # 050316-2 DATE: SHEET 1 OF 1		
ASSEMBLY REF:			