

# Compliant Utility Couplers

## Product Description

The Compliant Utility Coupler from ATI (patents pending) was designed for heavy-duty industrial applications where there is a need to change tools that pass utilities such as air and electrical signals in automated applications. The modular body design is capable of mounting any of ATI's standard add-on modules and is designed to improve cycle time and add flexibility to any production cell. The Master side connection features a unique compliance mechanism that allows for large tooling misalignments. A Utility Coupler can be provided with an ATI locking mechanism or a drive cylinder.

## Product Highlights

- Common mounting flats attach standard ATI modules
- Integrated fluid/air ports are available
- Engineered compliance to ensure flush mating
- DeviceNet™ compatible
- Optional drive cylinders
- Low-cost design

**The following two products are different variations of Utility Couplers that were engineered for specific applications. Contact ATI to determine if there is already a design that meets your requirements. We welcome the opportunity to design a Utility Coupler for your application.**

## Application Examples

The **QC-62 Quick Coupler** is used in conjunction with the compliant interface plate that complies to allow the Tool side to mate with the Master side evenly with just the weight of the tooling.

The compliant interface plate, along with ATI's patented locking mechanism, eliminates time-consuming and costly manual fixture adjustments in various automated applications. The modular square body design allows for the attachment of additional air/fluid utility modules, DeviceNet control modules, and Lock/Unlock and Ready-to-Lock sensing.

Master and Tool sides feature up to (4) mounting flats for passing utilities

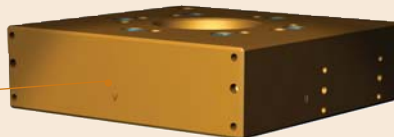

ATI's patented locking mechanism

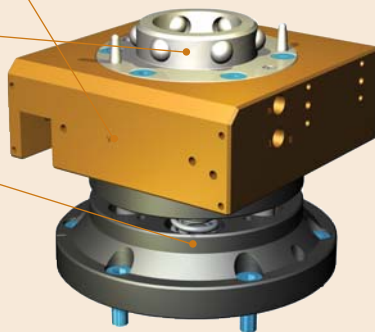

Compliant interface plate

Detection shaft for Lock/Unlock sensing

Compliance preload spring pattern provides centering repeatability

Compliance overload limiter

Thrust bearing

Locking cam

Hardened steel alignment pin

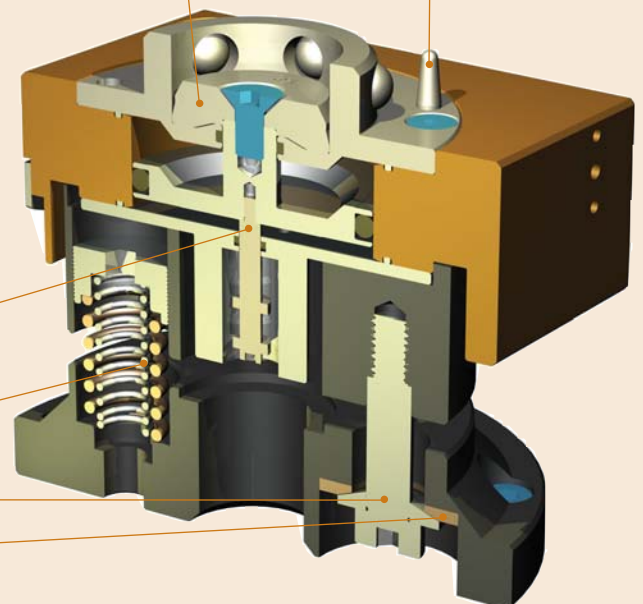

## Application Examples cont.

The **G2 Compliant Utility Coupler** meets the aggressive demands of changing tooling for framing gates. The Master side features an optional guided cylinder to provide the coupling force, and a unique compliance swivel joint that allows for severe misalignment of the Tool side prior to coupling. There are also two optional  $\frac{3}{4}$ " NPT checked ports integrated into the body of the coupler.

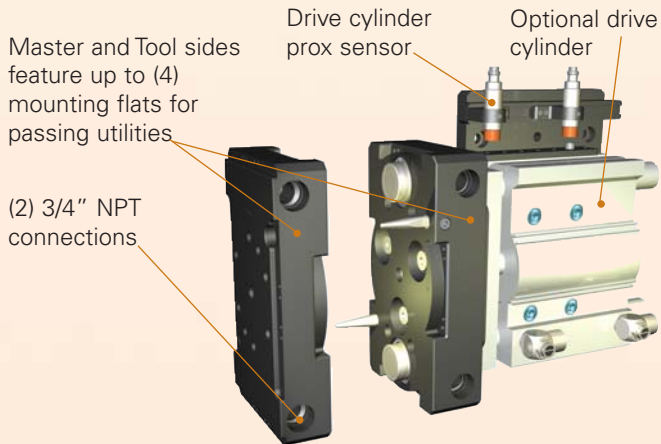

The rectangular body shape allows for easy mounting of additional peripheral utility modules such as DeviceNet, Fluid/Air, or Electrical. Because this coupler does not have a locking mechanism it offers greater flexibility enabling reduced tooling costs and cycle time.

Compliance preload spring pattern provides centering repeatability

Center swivel bearing

Compliance overload limiter

Thrust bearing

Hardened steel alignment pin

(2) checked air pass-through connections for  $\frac{3}{4}$ " NPT

